

Profile Scriber
PSC/1 -
PSC/50

INSTRUCTIONS

trend
routing technology

INST/PSC v4.0

Please
read carefully
before use

**PROFILE SCRIBER
REF. PSC/1 to PSC/50**

Thank you for purchasing this Trend router cutter set, which should give lasting performance if used in accordance with these instructions.

The following instructions apply to the Trend Profile Scriber range, whether fitted with a different shank size arbor or with other sizes of groovers or different profile blocks. (These instructions do not apply to the Easysset.®)

Instructions on the reverse have been written using the Profile Scriber Ref. PSC/1X1/2TC.

You will find in this box one Profile Scriber assembly and a shim set.

Profile Scriber sets should be used in a fixed position, either in an overhead or table routing machine, or in a portable router mounted in a fixed mode.

Profile Scriber sets fitted with an 8mm arbor can be used in smaller portable routers (with minimum 750 watts) fitted with an 8mm collet and used in a fixed mode. Please take many light passes with 8mm shank tooling.

⚠ Please note:
Before using cutter, please ensure it is correctly assembled and locking nut is fully tightened.

Classic Set

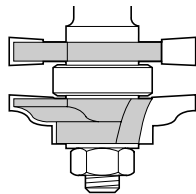

Instructions on the reverse have been written using this set.

Classic Decor

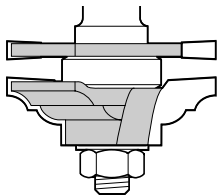

Classic Set

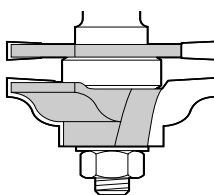

Flat Classic

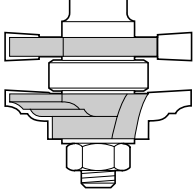

Bevel Panel

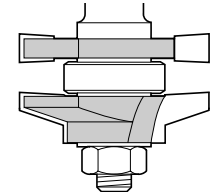

— Shim 0.05mm
— Shim 0.1mm

Each set is supplied with spare shims for use with the set after resharpening or if especially tight or loose joints are required.

Description	Material thick.		Order Ref.
	Min.*	Max.	
Classic Set With 6.3mm Groover With 4.0mm Groover	18mm 16mm	22mm 18mm	PSC/1 PSC/10
Classic Decor With 4.0mm Groover With 6.3mm Groover	18mm 21mm	22mm 26.5mm	PSC/4 PSC/40
Classic Set With 4.0mm Groover With 6.3mm Groover	18mm 21mm	22mm 26.5mm	PSC/2 PSC/20
Bevel Panel With 6.3mm Groover With 4.0mm Groover	18mm 16mm	22mm 18mm	PSC/5 PSC/50
Flat Classic With 6.3mm Groover With 4.0mm Groover	18mm 16mm	22mm 18mm	PSC/3 PSC/30

* When using PSC sets at the minimum material thickness, the height of the top quirk may be reduced.

Spare Parts	Order Ref.
Profile Block for PSC/1	SP-PSC/1A
Profile Block for PSC/2	SP-PSC/2A
Profile Block for PSC/3	SP-PSC/3A
Profile Block for PSC/4	SP-PSC/4A
Profile Block for PSC/5	SP-PSC/5A
Profile Block for PSC/10	SP-PSC/10A
Profile Block for PSC/20	SP-PSC/20A
Profile Block for PSC/30	SP-PSC/30A
Profile Block for PSC/40	SP-PSC/40A
Profile Block for PSC/50	SP-PSC/50A
Groover for PSC/1, PSC/3 & PSC/5	SP-34/70TC
Groover for PSC/2 & PSC/4	SP-34/71TC
Groover for PSC/10, PSC/30 & PSC/50	SP-34/70TC
Groover for PSC/20 & PSC/40	SP-34/70TC
Bearing 22mm Ø	BB22
Replacement Arbor 1/2"	33/30X1/2
Replacement Arbor 8mm	33/30X8mm
Alternative Arbor 12mm	33/30X12mm
Replacement Arbor Nut	A/NUT33/30
Spacer Set	SPACER/8

© Trend Machinery & Cutting Tools Ltd 2001 E & OE

Trend Machinery & Cutting Tools Ltd
Odhams Trading Estate St Albans Road
Watford WD24 7TR
Technical Support: 01923 224681
Fax: 01923 236879
Email: mailserver@trendm.co.uk
WWW: www.trendm.co.uk



PTO

Parts supplied in Set,
see diagrams overleaf

1. Arbor (x1)
2. Nut 13mm A/F (x1)
3. Profile Block (x1)
4. Groover (x1)
5. Ball Bearing 22mm Diameter (x1)
6. Washer 1.0mm Thick (x1)
7. Shims 0.1mm Thick (x3)
8. Shims 0.05mm Thick (x3)
9. Spacers 1.0mm Thick (x2) for PSC/20 & PSC/40 only
10. Spacer 6.00mm Thick (x1) for PSC/10, PSC/30 & PSC/50 only
11. Shim 0.5mm Thick (x1) for PSC/20 & PSC/40 only

The set is supplied in scribing mode. However parts 3 & 4 should be assembled 90° to each other to reduce cutting impact.

Changes in tightness can be achieved by adding or removing shims 7 & 8. This is most important after resharpening.

Cutters are re-arranged on the arbor to either cut the profile or the scribe.

The ball bearing will automatically give the correct depth of cut.

When re-assembling follow the sequence of the two diagrams.

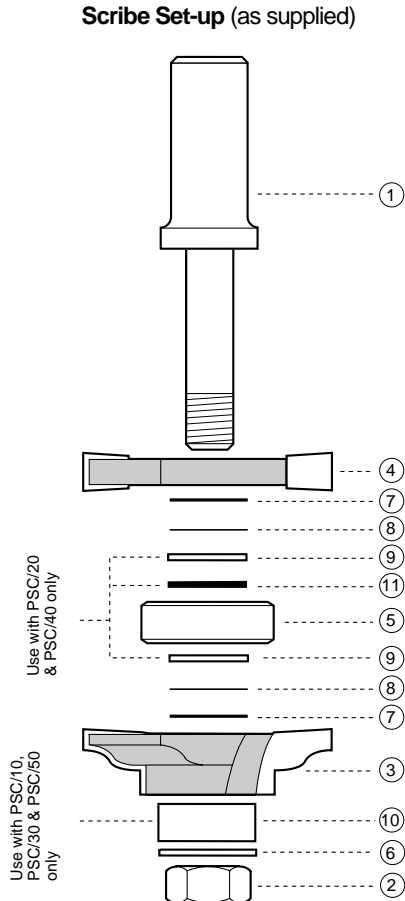

The assembly shown, is as supplied when purchased, but parts 3 & 4 should be assembled 90° to each other to reduce cutting impact.

This set-up is used for cutting the scribe across the ends of the rails. A workholder should be used as the rails will be too narrow to run against a fence. This also has the advantage of making the operation safer and more accurate.

The height of the cutter should be adjusted according to the thickness of the timber.

Spacers no.9 and no.11 are used on PSC/20 and PSC/40 sets only.

Spacer no.10 is used on PSC/10, PSC/30 and PSC/50 only.

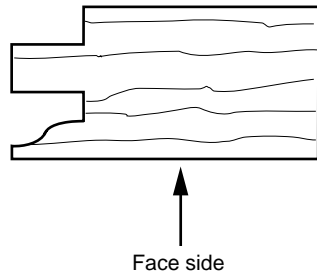

Profile Set-up

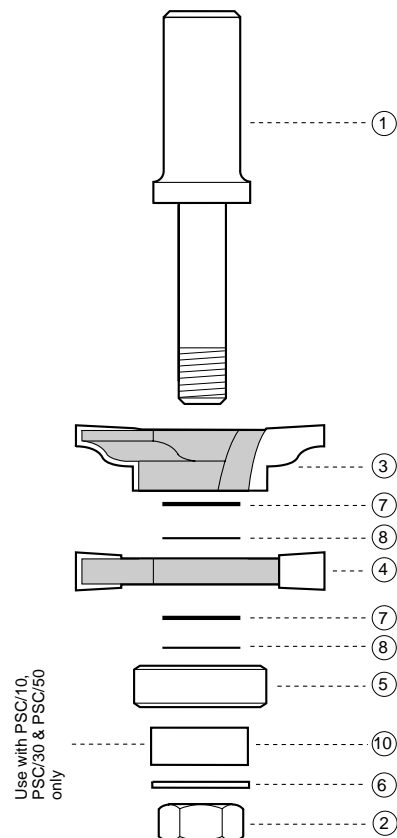

This assembly does the cutting of the profile along the wood. The wood should be inverted first. The height of the cutter should be adjusted according to the scribe.

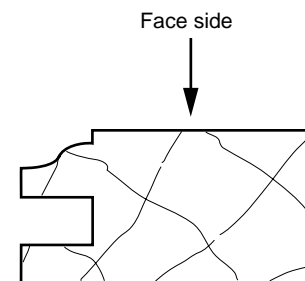

Safety Steps

1. Always wear eye protection such as goggles, ear protection and use effective respiratory protection.
2. Before making adjustments to the router, like changing the cutter, make sure the power is isolated correctly.
3. Before re-connecting to the mains supply, make sure the power switch on the router is in the 'off' position.
4. Do not switch on the router with the cutter in contact with the workpiece.
5. Before making adjustments always allow the cutter to stop rotating.
6. When routing keep your hands, hair and clothing clear of the cutter.
7. Make sure you follow the instructions which came with your router.
8. Ensure all visors, guards and dust extraction are fitted.
9. Trial cuts should be made in waste material before starting any project.

All Trend tooling is guaranteed against any defects in either workmanship or material, except tools that have been damaged due to improper use or maintenance.

Our policy of continuous improvements mean that specifications may change without notice. Trend Machinery & Cutting Tools Ltd cannot be held liable for any material rendered unusable, or for any form of consequential loss.