



## Minimach Template Seal MMACH/SEAL/1

Please  
read carefully  
before use



### MINIMACH TEMPLATE SEAL/GASKET REF. MMACH/SEAL/1

#### How to template and shape copy with the Minimach

To repeat a shape or a component accurately is traditionally a very time consuming business. Usually this involves pinning the workpiece to the template or using DST. The two components then must be held down to the bench before routing. This method also involves unnecessary time spent cleaning up or even filling the holes in the component.

A new process has been developed using the Minimach, which greatly simplifies this process. This is the Minimach template seal/gasket, which is 2.5 metres long x 10mm wide with a self-adhesive backed seal.

#### Operation:

1. Mark out and cut out the component or shape you wish to copy from a non-porous material i.e. melamine faced chipboard, blockboard, veneered/sealed M.D.F or plywood. The ideal thickness is 18mm or 3/4".
2. Ensure the edge of your template is smooth as any irregularity will be copied onto your workpiece as the bearing of the cutter follows it. Time spent on preparation of your template is always a wise investment.
3. Apply a single strip of self adhesive gasket material (supplied) round the edge of your template 3-5mm from the edge, cut the gasket ends at a slant as this helps the two ends to meet and seal.

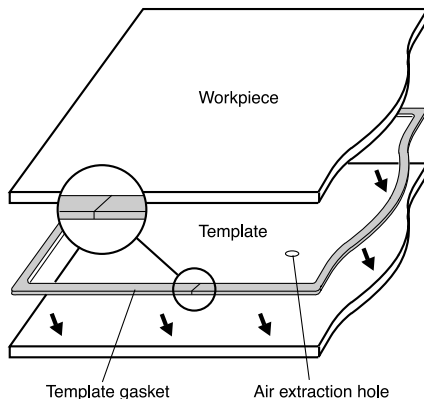

4. Drill an 8mm air extraction hole through the template.
5. Position the template on your workpiece, draw round your template and rough cut your workpiece to within 3-5mm of your template line. A band saw or jigsaw is ideal for this purpose.
6. Position the template on your Minimach covering as many complete cells as possible and ensuring that the air extraction hole is directly over an activated cell. This allows the Minimach (when switched on) to remove the air from between the workpiece and template, locking them together. (This grip may be stronger than the grip between the template and Minimach - this is entirely normal.) Check that the workpiece position allows an even overhang running right round the template.
7. Turn the vacuum control tap on and press the two down together holding the 2 parts for 2-3 seconds to allow the vacuum seal to form and the air to be drawn from between the components.
8. Prepare your router by fitting a bearing guided trimmer cutter and setting the depth stop to allow the bearing to run on the edge of the template edge.

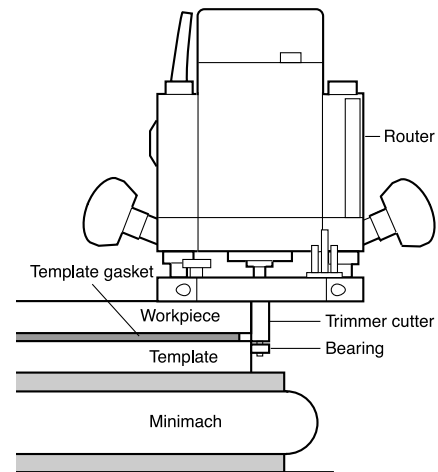

9. Before starting the cut check the template and workpiece are securely locked down.
10. Slowly route round the panel, a single cutting pass should be sufficient - only if the workpiece overhang exceeds 3mm might a second cutting pass be necessary.

Your copy should now be finished.

## Jigs - holding work for a full depth edge mould

This new method also allows work to be held exposing the full edge profile of the board for full - edge moulding. Even work that could not be held directly onto the Minimach can now be secured.

The diagram below shows a jig made to hold 50mm (2") strip for moulding.

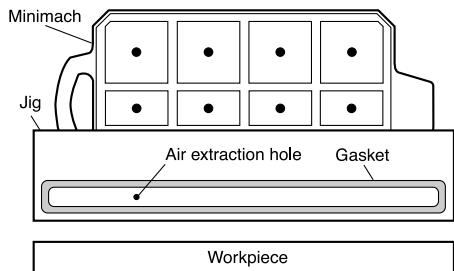

As with a normal workpiece, templates or jigs that overhang the Minimach should be supported.

## Holding framed doors

Any component that has a raised frame edge and that does not allow the central panel to contact and be gripped by the Minimach can be held via a jig - cut slightly smaller than the size of the central panel - gasketed and drilled like a template. When positioned, the jig will hold the panel in place keeping the frame off the Minimach.

We hope this new facility adds to your enjoyment of Minimach.

## Safety Steps

1. Always wear eye protection such as goggles, ear protection and use effective respiratory protection.
2. Before making adjustments to the router, like changing the cutter, make sure the power is isolated correctly.
3. Before re-connecting to the mains supply, make sure the power switch on the router is in the 'off' position.
4. Do not switch on the router with the cutter in contact with the workpiece.
5. Before making adjustments always allow the cutter to stop rotating.
6. When routing keep your hands, hair and clothing clear of the cutter.
7. Make sure you follow the instructions which came with your router.
8. Ensure all visors, guards and dust extraction are fitted.
9. Trial cuts should be made in waste material before starting any project.

**All Trend tooling is guaranteed against any defects in either workmanship or material, except tools that have been damaged due to improper use or maintenance.**

**Our policy of continuous improvements mean that specifications may change without notice. Trend Machinery & Cutting Tools Ltd cannot be held liable for any material rendered unusable, or for any form of consequential loss.**

© Trend Machinery & Cutting Tools Ltd 2002 E & OE

**Trend Machinery & Cutting Tools Ltd**  
Ochams Trading Estate St Albans Road  
Watford WD24 7TR  
Technical Support: 01923 224681  
Fax: 01923 236879  
Email: [mailserver@trendm.co.uk](mailto:mailserver@trendm.co.uk)  
WWW: [www.trendmachinery.co.uk](http://www.trendmachinery.co.uk)



RS 28982  
Stockholding  
& Supply



RECYCLABLE

