

# LOCK/JIG

Aluminium Adjustable  
Lever Type (Batch EB)



**trend**<sup>®</sup>  
routing technology



Please read these instructions before use.

Dear Customer

Thank you for purchasing this Trend product, we hope you enjoy many years of creative and productive use.

Please remember to return your guarantee card within 28 days of purchase.

## CONTENTS

<b>TECHNICAL DATA</b>	<b>1</b>
<b>SAFETY PRECAUTIONS</b>	<b>2-3</b>
<b>ITEMS ENCLOSED</b>	<b>4</b>
<b>DESCRIPTION OF PARTS</b>	<b>5</b>
<b>ACCESSORIES</b>	<b>6</b>
- Assembly	7
- Setting the Spacers	7
- Choice of Set-ups - Option 1	8
- Option 2	9
- Option 3	9
- Fitting the Guide Bush	10
- Steel Templates	11
- Template Selection Chart	11
- Special Note for Template 11	11
<b>OPERATION</b>	
- Marking Out	12
- Centring the Jig	13
- Quick Centring for 44mm doors	13
- Routing the Mortise	14
- Routing the Face-plate	14
- Finishing	15
- Deeper Mortise	15
- Cutting Key & Spindle Hole	15
<b>MAINTENANCE</b>	<b>15</b>
<b>ENVIRONMENTAL PROTECTION</b>	<b>15</b>
<b>GUARANTEE</b>	<b>15</b>
<b>SPARE PARTS</b>	
- Spare Parts List	16
- Spare Parts Diagram	1B

## TECHNICAL DATA

Cutter size	12mm
Min. workpiece	34mm
Max. workpiece	58mm
Template size	59.8mm x 239mm
Largest face plate inner aperture size	32mm x 177mm
Guide bush size	30mm
Weight	4.5kg

The following symbols are used throughout this manual:



Denotes risk of personal injury, loss of life or damage to the tool in case of non-observance of the instructions in this manual.



Refer to the instruction manual of your power tool.

This unit must not be put into service until it has been established that the power tool to be connected to this unit is in compliance with 2006/42/EC (identified by the CE marking on the power tool).

## INTENDED USE

This jig is intended for use with a plunge router with suitable guide bush and router cutter fitted to rout a mortise and face plate for locks in wooden doors.



If you require further safety advice, technical information or spare parts, please call Trend Technical Support or visit [www.trend-uk.com](http://www.trend-uk.com)

### SAFETY

#### WARNING:



Observe the safety regulations in the instruction manual of the power tool to be used. Please read the following instructions carefully. Failure to do so could lead to serious injury. When using electric tools, basic safety precautions, including the following should always be followed to reduce the risk of fire, electric shock and personal injury. Also observe any applicable additional safety rules. Read the following safety instructions before attempting to operate this product.

#### PLEASE KEEP THESE INSTRUCTIONS IN A SAFE PLACE.

The attention of UK users is drawn to The Provision and Use of Work Equipment Regulations 1998, and any subsequent amendments.

Users should also read the HSE/HSC Safe Use of Woodworking Machinery Approved Code of Practice and Guidance Document and any amendments.

Users must be competent with woodworking equipment before using our products.

#### IMPORTANT NOTE:

Residual Risk. Although the safety instructions and operating manuals for our tools contain extensive instructions on safe working with power tools, every power tool involves a certain residual risk which cannot be completely excluded by safety mechanisms. Power tools must therefore always be operated with caution!

#### General

1. Disconnect power tool and attachment from power supply when not in use, before servicing, when making adjustments and when changing accessories such as cutters. Ensure switch is in "off" position. Always ensure cutter has stopped rotating.
2. Always mount the power tool, accessory or attachment in conformity with the instructions. Only use attachment and accessories specified in the power tool manual. The tool or attachment should not be modified or used for any application other than that for which it was designed. Do not force tool.
3. Keep children and visitors away. Do not let children or visitors touch the tool, accessory or attachment. Keep children and visitors away from work area. Make the workshop child proof with padlock and master switch.
4. Dress properly. Do not wear loose clothing or jewellery, they can be caught in moving parts. Rubber gloves and non-skid footwear is

recommended when working outdoors. Wear protective hair covering to contain long hair.

5. Consider working environment. Do not use the product in the rain or in a damp environment. Keep work area well lit. Do not use power tools near gasoline or flammable liquids. Keep workshop at a comfortable temperature so your hands are not cold. Connect machines that are used in the open via a residual current device (RCD) with an actuation current of 30 mA maximum. Use only extension cables that are approved for outdoor use.
6. The accessory or attachment must be kept level and stable at all times.
7. Keep work area clean. Cluttered workshops and benches can cause injuries. Ensure there is sufficient room to work safely.
8. Secure idle tools. When not in use, tools should be stored in a dry and high or locked up place, out of reach of children.
9. For best control and safety use both hands on the power tool and attachment. Keep both hands away from cutting area. Always wait for the spindle and cutter to stop rotating before making any adjustments.
10. Always keep guards in place and in good working order.
11. Remove any nails, staples and other metal parts from the workpiece.
12. Maintain tools and cutters with care. Keep cutters sharp and clean for better and safer performance. Do not use damaged cutters. Follow instructions for lubricating and changing accessories. Keep handles dry, clean and free from oil and grease.
13. Maintain accessories. Do not use damaged accessories. Only use accessories recommended by the manufacturer.
14. Check damaged parts. Before operation inspect the attachment, the power tool, the cable, extension cable and the plug carefully for signs of damage. Check for alignment of moving parts, binding, breakage, mounting and any other conditions that may effect its operation. Have any damage repaired by an Authorised Service Agent before using the tool or accessory. Protect tools from impact and shock.
15. Do not use tool if switch does not turn it on or off. Have defective switches replaced by an Authorised Service Agent
16. Don't over reach. Keep proper footing

and balance at all times. Do not use awkward or uncomfortable hand positions.

17. Don't abuse the cable. Never carry power tool or accessory by cord or pull it to disconnect from the socket. Keep cord from heat, oil and sharp edges. Always trail the power cord away from the work area.
18. Connect dust extraction equipment. If devices are provided for the connection of dust extraction and collection facilities, ensure these are connected and properly used.
19. Check all fixing and fastening nuts, bolts and screws on power tool, attachment and cutting tools before use to ensure they are tight and secure. Periodically check when machining over long periods.
20. Stay alert. Watch what you are doing. Use common sense. Do not operate tools when you are tired, under the influence of drugs or alcohol.
21. Personal Protective Equipment (PPE) for eye, ear and respiratory protection must be worn. All PPE must meet current UK and EU legislation.
22. Do not leave tools running unattended. Do not leave tool until it comes to a complete stop.
23. Always clamp workpiece being machined securely.
24. Only use cutting tools for woodworking that meet EN847-1/2 safety standards, and any subsequent amendments.
25. Vibration levels. Hand held power tools produce different vibration levels. You should always refer to the specifications and relevant Health & Safety Guide.

#### Routing Safety

1. Read and understand instructions supplied with power tool, attachment and cutter.
2. Keep hands, hair and clothing clear of the cutter.
3. Remove adjusting keys and spanners. Check to see that keys and adjusting spanners are removed from the router tool, cutter and attachment before turning router on. Make sure cutter can rotate freely.
4. Noise. Take appropriate measures for the protection of hearing if the sound pressure of 85dB(A) is exceeded. Routing sound pressure may exceed 85dB(A), so ear protection must be worn.
5. Eye protection. Always wear eye protection in the form of safety goggles, spectacles or visors to protect the eyes.

6. Respiratory protection. Wear a face or dust mask, or powered respirator. Dust masks/filters should be changed regularly.
7. Do not switch router on with the cutter touching the workpiece. At the end of the cut, release the router plunge and allow spindle to stop rotating. Never use the spindle lock as a brake
8. The direction of routing must always be opposite to the cutter's direction of rotation. Do not back-cut or climb-cut.
9. Check before cutting that there are no obstructions in the path of the router. Ensure there are no obstacles beneath workpiece when cutting full thickness, and that a sacrificial work surface is used.

**Router Cutter Safety**

1. Cutting tools are sharp. Care should be taken when handling them. Do not drop cutters or knock them against hard objects. Handle very small diameter cutters with extra care. Always return cutter to its packaging after use.
2. Always use cutters with a shank diameter corresponding to the size of the collet installed in your tool.
3. The maximum speed (n.max) marked on the tool, or in instructions or on packaging shall not be exceeded. Where stated the speed range shall be adhered to. Recommended speeds are shown in the Trend Routing Catalogue and/or website.
4. Always use router cutters in a router. Drill and boring bits must not be used in a router. Router cutters must only be used for the material cutting application for which they are designed. Do not use on metal or masonry.
5. Never use cutters with a diameter exceeding the maximum diameter indicated in the technical data of the powertool or attachment used.
6. Before each use check that the cutting tool is sharp and free from damage. Do not use the cutting tool if it is dull, broken or cracked or if in any other damage is noticeable or suspected.
7. Cutters should be kept clean. Resin build up should be removed at regular intervals with Resin Cleaner<sup>®</sup>. The use of a PTFE dry lubricant will reduce resin build up. Do not use PTFE spray on plastic parts.
8. When using stacked tooling (multi-blade, block and groover etc.) on a spindle arbor, ensure that the cutting edges are staggered to each other to reduce the cutting impact.
9. Cutter shanks should be inserted into the collet all the way to the line

indicated on the shank. This ensures that at least ¾ of the shank length is held in the collet. Ensure clamping surfaces are cleaned to remove dirt, grease, oil and water.

10. Observe the correct assembly and fitting instructions in the router instruction manual for fitting the collet, nut and cutter.
11. Tool and tool bodies shall be clamped in such a way that they will not become loose during operation. Care shall be taken when mounting cutting tools to ensure that the clamping is by the shank of the cutting tool and that the cutting edges are not in contact with each other or with the clamping elements.
12. It is advisable to periodically check the collet and collet nut. A damaged, worn or distorted collet and nut can cause vibration and shank damage. Do not over-tighten the collet nut
13. Do not take deep cuts in one pass; take several shallow or light passes to reduce the side load applied to the cutter and router. Too deep a cut in one pass can stall the router.
15. In case of excessive vibrations whilst using the router stop immediately and have the eccentricity of the router, router cutter and clamping system checked by competent personnel
15. All fastening screws and nuts should be tightened using the appropriate spanner or key and to the torque value provided by the manufacturer.
16. Extension of the spanner or tightening using hammer blows shall not be permitted.
17. Clamping screws shall be tightened according to instructions provided by the manufacture. Where instructions are not provided, clamping screws shall be tightened in sequence from the centre outwards.

**Using Routers In A Fixed Position**

1. Attention should be made to the HSE's Safe Use of Vertical Spindle Moulding Machines Information Sheet No.18 and any revisions.
2. After work, release the router plunge to protect the cutter.
3. Always use a push-stick or push-block when making any cut less than 300mm in length or when feeding the last 300mm of the cut.
4. The opening around the cutter should be reduced to a minimum using suitably sized insert rings in the table and closing the back fence cheeks or fitting a false fence on the back fence.
5. Whenever possible use a work

holding device or jig to secure component being machined. Ensure any attachment is securely fitted to the workbench, with table surface at approximately hip height.

6. Use a No-Volt Release Switch. Ensure it is fixed securely, easily accessible and used correctly.
7. In router table (inverted) mode, stand to the front right of the table. The cutter will rotate anti-clockwise when viewed from top so the feed direction is from the right (against the rotation of the cutter). In overhead mode, stand to the front left of the machine table and the feed direction is from the left.
8. Do not reach underneath table or put your hands or fingers at any time in the cutting path while tool is connected to a power supply.
9. Never thickness timber between the back of the cutter and the backfence.

**Useful Advice When Routing**

1. Judge your feed rate by the sound of the motor. Feed the router at a constant feed rate. Too slow a feed rate will result in burning.
2. Trial cuts should be made on waste material before starting any project.
3. When using some attachments e.g. a router table or dovetail jig, a fine height adjuster is recommended.
4. When using a template guide bush, ensure there is sufficient clearance between cutter tip and inside edge of bush and that it cannot come into contact with collet and nut. Ensure cutter and guide bush are concentric.

**Router Cutter Repair/Maintenance**

1. Repair of tools is only allowed in accordance with the manufacturers instructions.
3. The design of composite (tipped) tools shall not be changed in process of repair. Composite tools shall be repaired by a competent person i.e. a person of training and experience, who has knowledge of the design requirements and understands the levels of safety to be achieved.
4. Repair shall therefore include, e.g. the use of spare parts which are in accordance with the specification of the original parts provided by the manufacturer.
5. Tolerances which ensure correct clamping shall be maintained.
6. Care shall be taken that regrinding of the cutting edge will not cause weakening of the body and the connection of the cutting edge to the body.

**ITEMS ENCLOSED**

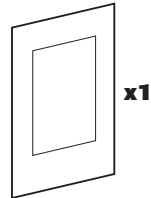
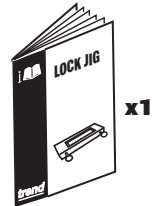
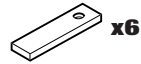
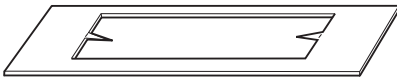
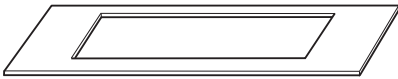
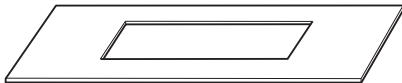
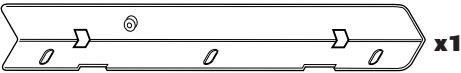
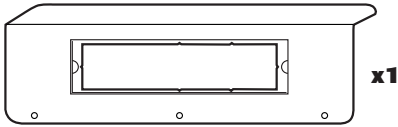

**ITEMS REQUIRED**

- 1/2" collet plunge router (or 1/4" collet plunge router for face plate only).
- 30mm guide bush (or 16mm plus collar).
- 12mm diameter router cutter with suitable shank size.
- Door clamping device.
- Hand tools.
- No. 2 Phillips Screwdriver.

**DESCRIPTION OF PARTS**

Use the drawing below as a guide to assemble the jig.

- (A) Jig body
- (B) Adjustable lever fixing stud
- (C) Clamp bar (datum)
- (D) Adjustable lever washer
- (E) Adjustable lever M8
- (F) Spacer finger fixing stud
- (G) Spacer finger
- (H) Spring washer
- (I) Mini knob M5
- (J) Guide bush collar 16mm to 30mm
- (K) Collar park
- (L) Mortise template
- (M) Face plate template
- (N) Clamping knob with pad
- (O) Jig template aperture recess
- (P) Central aperture
- (Q) Line-up Template

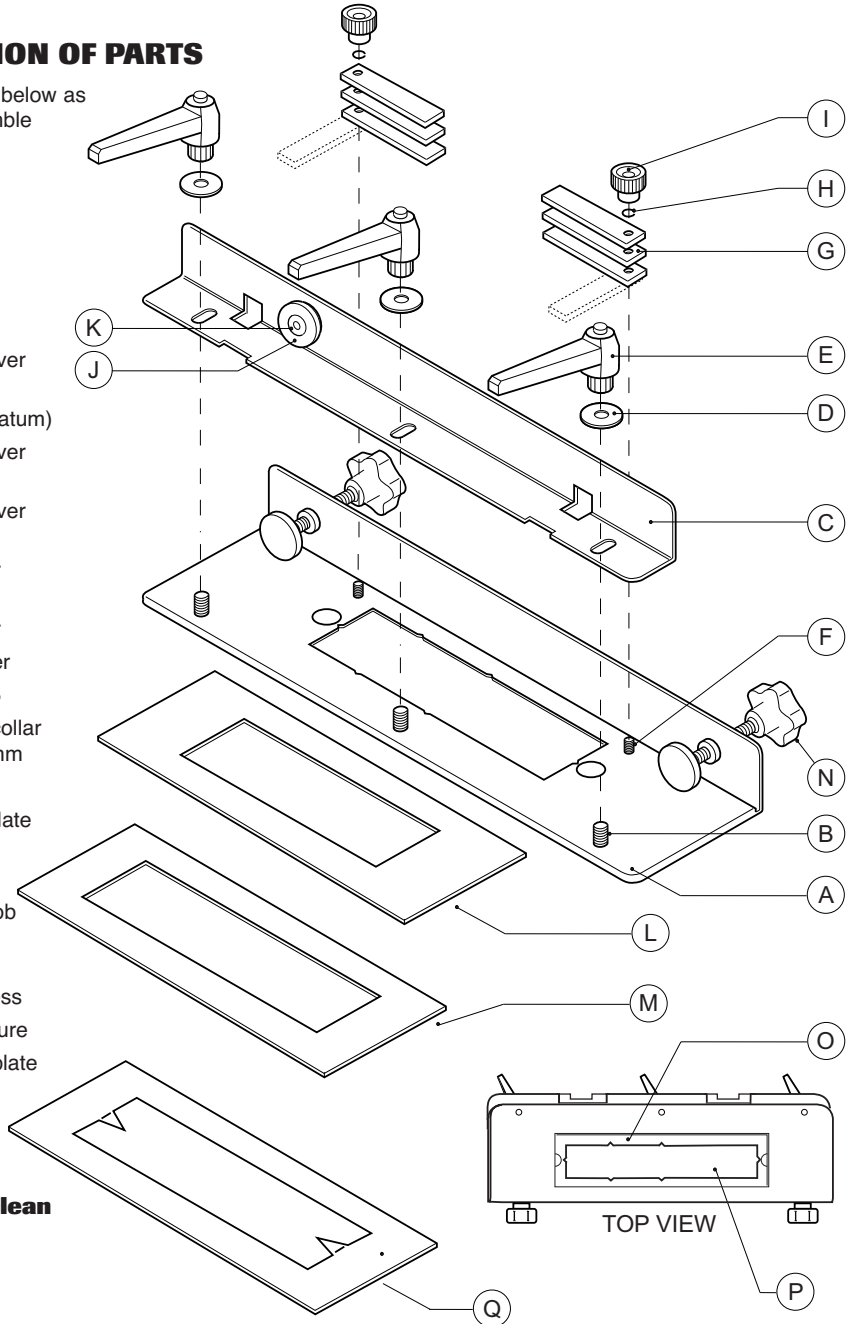

**Ensure jig is clean and free of oil before use.**

**ACCESSORIES**

Please use only Trend original accessories.

**30mm Guide Bush**

Ref. GB30

Should the correct guide bush not be available to suit your router's base, you will need to use the Trend UNIBASE in conjunction with a 30mm guide bush, Ref. GB30 or 16mm guide bush Ref. GB160.

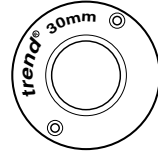

**Universal Sub-base**

Ref. UNIBASE

The Unibase contain screws, a line up bush and pin. The line up pin and bush ensure exact alignment of sub-base with the router spindle, when fitted with the relevant collet.

**Fits following router models**

Atlas Copco OFSE2000 Bosch GOF 1300ACE, 1600A, 1700ACE Casals FT2000VCE CMT CMT1850, 2000, DeWalt DW624, 625EK, 629 Draper R1900V Elu MOF 131, 177(E) Felisatti TP246(E), R346EC Festo OF2000E Freud FT2000E Hitachi M12V, M12SA, TR12 Metabo OF1612, OFE1812 Ryobi RE600N, R600N, RE601, R500, R502 Skil 1875U1 Wadkin R500

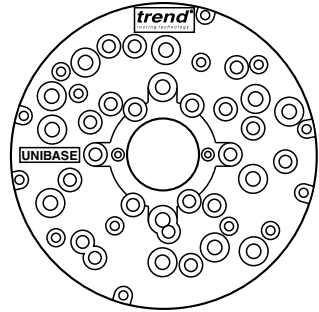

**Door Stand**

Ref. D/STAND/A

Holds door on it's edge whilst routing hinge recess and mortise for locks. Maximum weight 50kg and for doors 32mm to 55mm thick. Allows door to be tilted back to assist fitting to door frame.

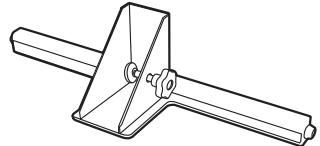

**Door Clamp**

Ref. D/CLAMP/A

Holds door whilst drilling and fitting locks. Ratchet clamp design for doors up to 55mm thick.

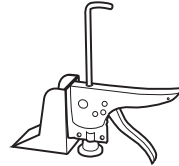

**Corner Chisel**

Ref. C/CHISEL

Squares up rounded corners in one operation. High speed steel. Use with a hammer.



**24" Carry Case**

Ref. CASE/DH

Accepts Door Stand, Lock Jig, Door Clamp and accessories.

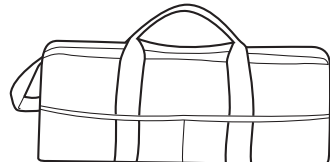

**ASSEMBLY**

- Remove the transit washer and nut from the middle adjusting lever fixing stud (2) on the jig body (1). Fit the three washers (4), and fit the three adjustable levers (5). To tighten the adjustable levers, lift the lever up and rotate the knurled part whilst keeping the lever body stationary. When hand-tight, release the ratchet and tighten using the lever.
- Remove the protective film from the spacer fingers (7) then place three spacer fingers onto the spacer finger fixing bar (6). See Setting the Spacers (right) for adjustment. Fit the spring washer (8) and the mini knob (9) onto the spacer finger fixing stud (6) and tighten. Repeat procedure for other assembly.



**On timber that is over 56mm thick it may be necessary to remove the M5 knobs and use two accessory M5 hex nuts ref WP-NUT/05 (1 off) to secure.**



**In some circumstances when a guide bush with a long spigot is used it may contact the clamping bar, if this occurs a shallower spigot guide bush will be required.**

**Special Note:**

The Lock Jig can be used to cut the face-plate recess in the edge of doors whilst it is hung.



**The mortise should NOT be routed when the door is hung. Always ensure that the door is firmly secured if routing the face-plate on a hung door, so there is no possibility of the door swinging open or shut.**

**Setting the Spacer Fingers**

- Spacers may need to be used to ensure the spigot of the guide bush will not contact the door edge when routing.
- Three spacers per end of the jig are provided and can be parked against the jig body when not required.
- Clamp the jig to the door and place the router fitted with guide bush into the aperture. If the guide bush does not contact the door edge, then no spacers need to be used.
- If the guide bush contacts the door edge calculate how many spacers are required. Each spacer is 2mm thick.
- To reposition the spacers, undo each of the two M5 knobs, remove knob and washer and lift off the spacers. Reposition the required number of spacers by 90° so they line up across the jig and replace all unused spacers. Ensure an equal number of spacers are used at each end. Refit the washers and the M5 knobs and tighten.

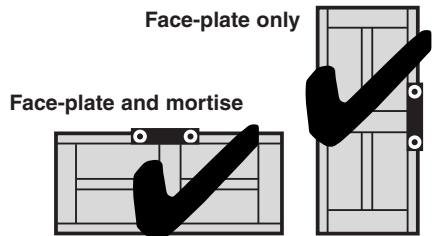
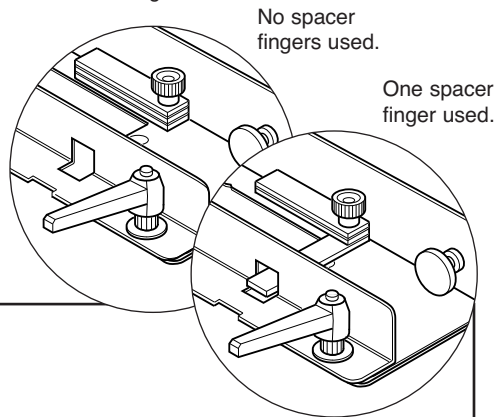



**Choice of Set-ups  
Option 1**

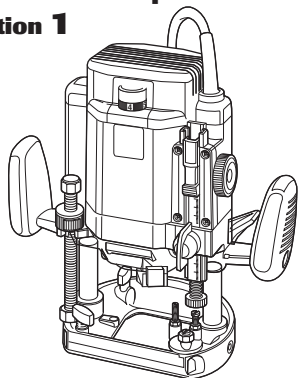

Heavy duty router with 1/2" collet e.g. T10/T11 Router

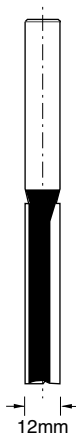

Router Cutter  
Ref. TR37X1/2TC  
overall length 115mm

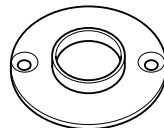

30mm Guide  
Bush Ref. GB30

See page 8 if a suitable guide bush is not available for your router.

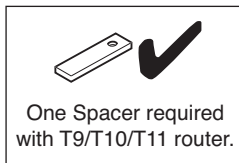

**Suitable Plunge Router:**

Your router should have following plunge length:

- For 2" deep locks at least 54mm.
- For 2 1/2" deep locks at least 66mm.
- Auger bit and drill required for 3" deep locks for all routers.

**OR USE**

Router Cutter  
Ref. TR37MX1/2TC  
overall length 100mm  
with the following routers:

- RYOBI R600, R600(N)  
RE601
- Makita 3612(C)
- Skil 1875U1



**Fit sufficient length of the shank into the collet. Ideally at maximum plunge, only as much of the cutter should protrude below the base as is required to reach the depth of the mortise.**



**Due to the extra long length of this cutter, extra care should be taken to avoid damage. The cutter should be used to plunge rout a series of overlapping holes. See page 13.**



**Do not attempt to increase the depth of cut by having less than the optimum length of the cutter's shank inserted in the collet of your router.**



**The guide bush Ref GB30/A cannot be used with the jig for internal doors.**

**Option 2**

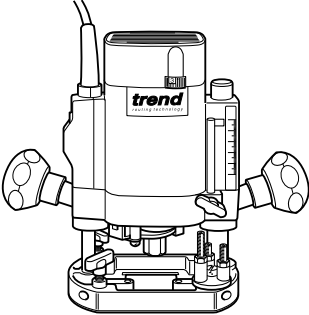

Medium duty router with  
1/4" collet e.g. T5 Router

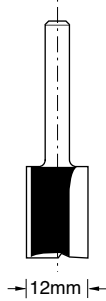

Router Cutter  
Ref. TR12X1/4TC  
overall length 70mm

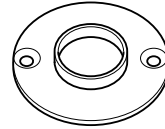

30mm Guide Bush  
Ref. GB30

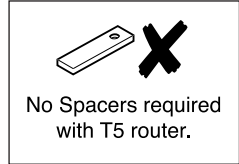

**OR USE**

Router Cutter  
Ref. 3/8LX1/4TC  
overall length 66mm

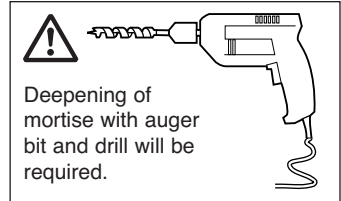

**Option 3**

**Using the Lock Jig with the Trend Hinge Jig**

- If the Lock Jig is to be used in conjunction with the Trend Hinge Jig, use the Guide Bush Collar to bush out the 16mm guide bush (supplied with the Hinge Jig) to 30mm diameter. This makes it unnecessary to change guide bushes between operations.

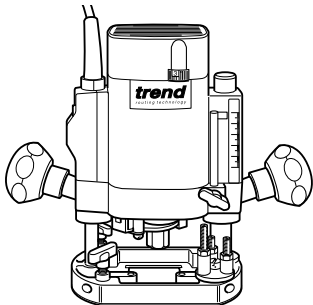
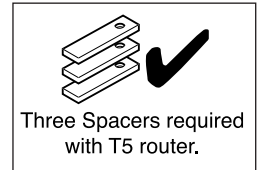

Medium duty router with  
1/4" collet e.g. T5 Router

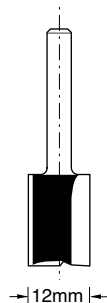

Router Cutter  
Ref. TR12X1/4TC  
or 3/8LX1/4TC

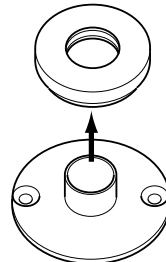

Guide Bush Collar  
Ref. GB/COLL/1630  
Supplied with Lock Jig

16mm Guide  
Bush Ref.  
GB160  
Supplied with  
Hinge Jig

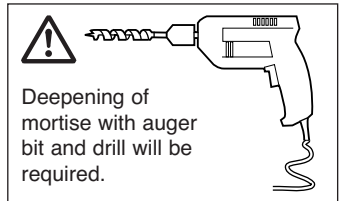

**Fitting the Guide Bush**

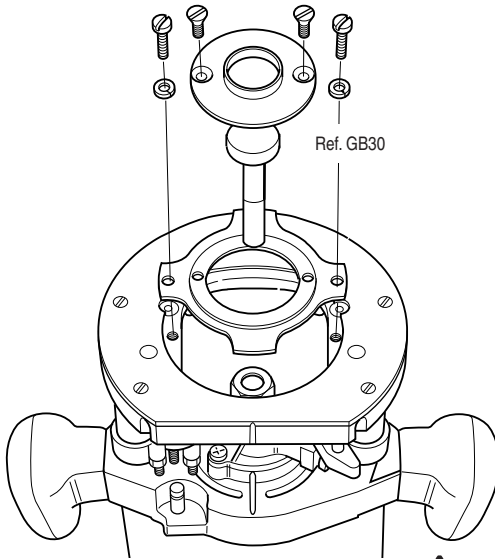

Ref. GB30



**Fitting Guide Bush to T10/T11 Router**

- If using the Trend T10/T11 Router, fit a 30mm guide bush Ref. GB30. Make sure the bush is correctly centred.



**If there is any doubt about the concentricity of cutter relevant to the guide bush, then a sub-base should be used in order to ensure an accurate fit of face-plate.**



**Ensure guide bush collar is fitted fully onto the guide bush with chamfer facing the jig.**



**Frequently check that the guide bush collar is seated properly on the the guide bush. Check that the collar has not worked loose otherwise this will affect the cut.**

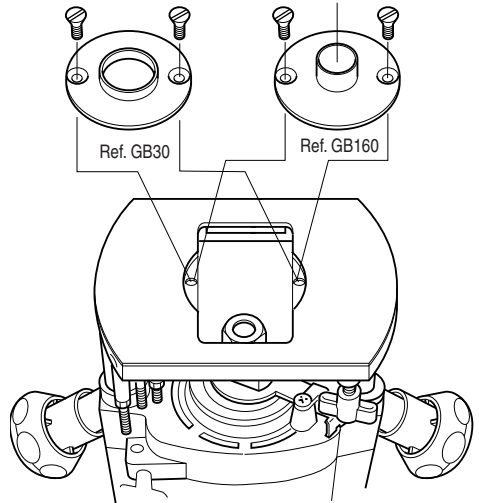

Ref. GB30

Ref. GB160

**Fitting Guide Bush to T5 Router**



- If using the Trend T5 Router, purchase and fit a GB30.
- If using the Hinge Jig, fit the GB160 supplied with the Hinge Jig. By using the Guide Bush Collar supplied with the Lock Jig, the same router set-up can be used by simply fitting the collar in between the hinge and lock operations.
- The guide bush collar can be stored on the spigot fixed to the outside of the clamp bar when not in use.

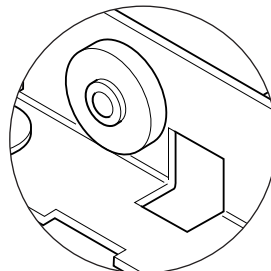

Make sure guide bush collar is fitted with chamfered edge facing the jig when parked. This will make it easier to remove.

### Steel Templates

- Mortise templates (letters A,B,C etc.) have smaller apertures for the lock body and face-plate templates have a larger aperture (numbered 1, 2, 3 etc.).

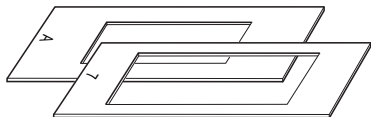

- They are attached to the jig by means of the two strong magnets incorporated in the jig body. Ensure that the seating for template is free of wood dust.
- The templates are reversible and have no defined top or bottom (except template 11, see below right).
- A laminated loose sheet 'Look-up Chart' is supplied with this manual showing popular makes of lock and their correct template selection.
- If your lock is not listed use the chart above right to calculate which two plates are required for the mortise and face-plate eg. B7.
- For the latest information on templates available, see our website - [www.trend-uk.com/downloads](http://www.trend-uk.com/downloads) or call Trend Technical Support.



**Before using the face-plate template check the template is exactly 18mm bigger than the actual lock face plate.**

### Special Note for Template 11

- Template 11 is used for 1" mortise latches. Two aperture sizes are offered in the one template, to cater for the two popular sizes of mortise latch face-plates available.
- The upper aperture will suit a latch plate 25mm x 57.5mm. The lower aperture will suit a latch plate 25.6mm x 56.5mm.
- Two additional centre line notches on the jig body are used in conjunction with this template.
- Ensure you accurately measure the face-plate before selecting the appropriate aperture.
- The mortise for the latch body should be cut with a suitable auger bit and drill.



**Please note templates have square corners so care must be taken when handling.**

### Template Selection Chart

#### Face-plate Dimensions:

Approx. Imperial	Metric	Select Template
7/8" x 6 1/8"	22.2 x 156mm	1
7/8" x 6"	22.5 x 152.5mm	2
1" x 4 3/4"	25.4 x 121mm	3
1" x 5"	25.4 x 127.5mm	4
1" x 5 1/4"	25.4 x 133.5mm	5
1" x 5 3/4"	25.4 x 145mm	6
1" x 6"	25.4 x 153mm	7
1" x 6 1/8"	25.4 x 156mm	8
1" x 6 1/2"	25.4 x 165.5mm	9
1" x 7"	25.4 x 177mm	10
1" x 2 1/4"	25 x 57.5mm	11 UPPER
1" x 2 1/4"	26 x 56.5mm	11 LOWER
1" x 6 3/8"	25.6 x 162mm	12

#### Mortise Dimensions:

Approx. Imperial	Metric	Select Template
5/8" x 2 7/8"	16 x 72mm**	A
5/8" x 4 1/4"	16 x 107mm*	B
3/4" x 3 1/8"	19 x 79mm*	C
3/4" x 4 1/4"	19 x 109mm*	D

\* These are maximum mortise lengths, unless radius ends are squared with a chisel. However, smaller mortise locks can be accommodated depending on the position of their fixing screws.

+ Note actual size of mortise is 16mm x 79mm (5/8" x 3 7/16").

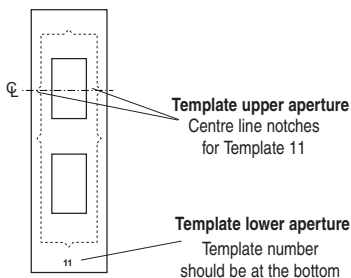

**Make sure the correct templates are used eg A,B,C etc for the mortise, and 1,2,3 etc for the face-plate.**

**OPERATION**



**Marking Out**

- Choose the position of the lock carefully. Position the lock with the centre of the spindle aperture at approximately 1m above the floor. Whilst the lock is on the edge of the door, mark the top and bottom of the lock case on the door edge. Do not choose a position where the cross member joins the stile as it will weaken the door.
- Then using a marking gauge set to half the thickness of the door, join the marks to show where the centre line of the mortise lock will be. Ensure the centre line is long enough to sight them on the centre line notches on the jig body.
- Mark a horizontal line across the edge at the centre of your lock position. You now have two centre lines to line up with the notches on the jig body.

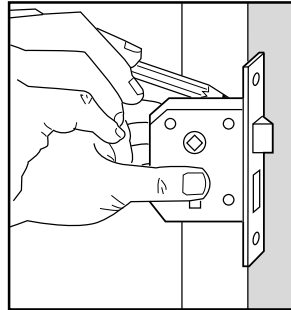

**Please note, the centre of the mortise may not be on the centre line of the spindle hole.**

- Mark out the spindle and keyhole position on the face of the door as normal using a paper template or the lock body as shown with a bradawl (ensuring the front of the lock is flush with the door edge).

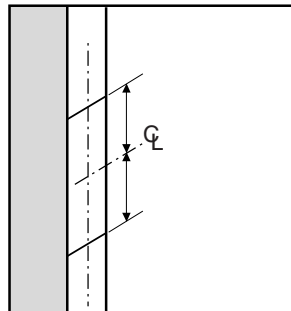

**Ensure working position is comfortable, especially when setting up and when routing a door edge.**



**Ensure door is clamped and held securely when using the jig.**

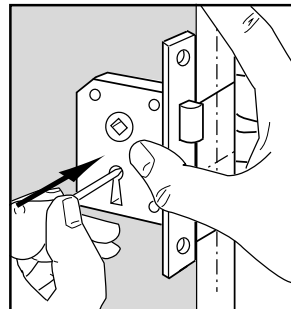

**Special Note**

If fitting the lock to a non-solid core door, ensure the lock block is located first.

**Centring the Jig**

When using the Lock Jig, the clamp bar is used as the datum edge. Before the jig can be used the clamp bar datum has to be set by the user.

The jig central aperture has v notches that are punched into the jig body. Due to manufacturing tolerances the v notches should only act as an initial guide to position the jig on the door.

Furthermore when the spacer fingers are used this raises the jig higher making it more difficult to align to the pencil marks.



**The central aperture notches are to be used as an initial visual guide only, always check the jig and template is centred to the door before routing.**

The laser cut line-up template has two v-point wings that are bent down so that they are closer to the door edge when fitted into the jig and ensure the jig can be set up more accurately. The v-point wings denote the centre of the line up plate.

The v-point wings have been bent down to take into account the jig plate thickness when no finger spacers are used. If the jig is being used with finger spacers the v-point wings can be bent down further at the fold line with a pair of pliers to the required height.



**Please note v-point wings are sharp. Please handle with care.**

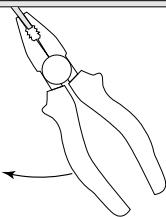
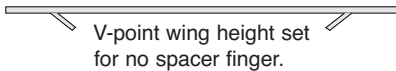

Pliers can be used to bend back the v-point wing when spacer fingers are used.



**Trial cuts should be made on waste material to check correct templates have been selected and that jig is set up accurately.**

To set up jig with the line-up template

- After the lock position has been marked on the door with a pencil, loosen the two lobe clamping knobs and the three adjustable levers (ratchet type which will require lifting to change their position) so that the jig can fit to the door.
- Place line-up template into template aperture recess of jig, ensure the v-point wings point downward.
- To set the jig accurately, adjust the two clamping knobs to move the jig forward or backwards to centre the v-point wings to the pencil line on the door. Once the jig is centred and parallel, slide the clamping knob against the door edge and tighten the adjustable levers.

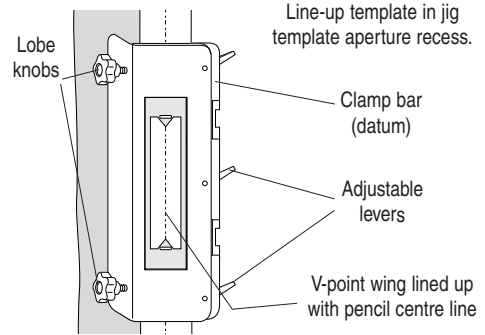

- Check clamping bar is fully against the door edge and adjust adjustable levers if necessary. The datum has now been set.
- Remove line-up template and store carefully.
- The jig can now be clamped into position by tightening the two lobe knobs. Only gentle pressure is required.



**Do not over-tighten lobe knobs as damage to the door or jig may occur. Adjustable levers may require the machine screw to be tightened with a No.2 Phillips screwdriver before use.**

- Fit correct mortise or faceplate template into jig for the actual mortise/face-plate required.

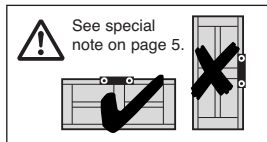

### Routing the Mortise

- Fit the relevant mortise template to the jig body eg A, B, C etc. Ensure that seating for template is free of wood dust. Template may need to be tilted (long edge first) into the jig template aperture recess to fit.
- Plunge rout the mortise by drilling a series of overlapping holes no more than 20mm deep.
- Make sure plunge locking lever of router is locked and then clean up by making a shallow pass no more than 20mm around the template in a clock-wise direction.
- Remove loose waste with a screwdriver and vacuum extractor and repeat plunge and rout operations until full depth is achieved.
- Depending on router set-up, deepening of mortise with auger bit and drill may be required.

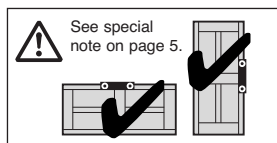

### Routing the Face-plate

- Fit the relevant face-plate template eg 1, 2, 3 etc. Ensure seating is clear of any wood dust or swarf. Template may need to be tilted (long edge first) into the jig template aperture recess to fit.
- Zero the depth of the cutter, by lowering it until it touches the door edge.
- Insert the lock fixing plate together with the face-plate between the revolving depth guide and the fine adjuster screw. Lower the fine adjuster (1) and lock it off (2) see picture.
- Release the plunge locking lever.
- To rout the face-plate, plunge cutter to full depth of face-plate in the middle of the template and lock off plunge.
- Rout in a clockwise direction to the set depth. Release the plunge locking lever.

After use of the jig, keep jig assembled and store carefully.

Plunge rout a series of holes

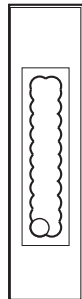

Rout clockwise for clean up

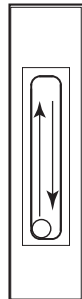

**Rout in shallow passes. Do not attempt to increase the depth of cut by having less than the optimum length of the cutter's shank inserted in the collet of your router. Trial cuts should be made on waste material to check the fit before routing the door.**



**To set cutter plunge depth measure the depth of the lock body from the face to the back and add 3mm to allow for clearance.**

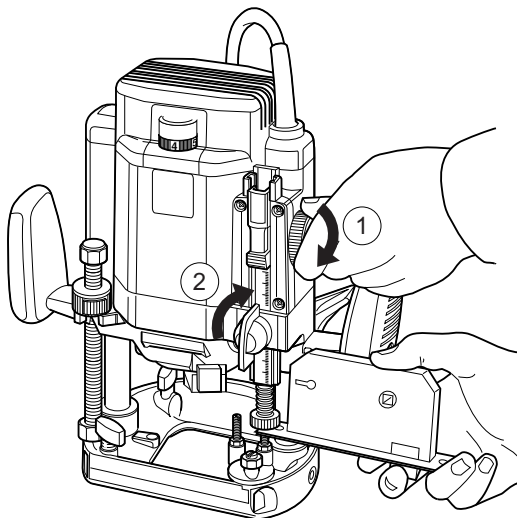

**Finishing** 

- The corners of the face-plate recess will need squaring off with a sharp chisel. Alternatively the Trend Corner Chisel Ref. C/CHISEL, can be used to square off the rounded corners with one tap of a hammer.

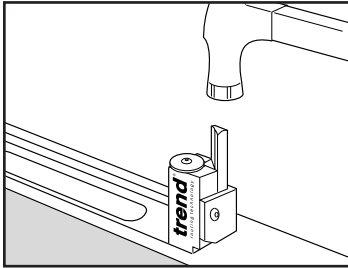

**Deeper Mortise** 

- Should you need to cut the mortise deeper than the maximum depth possible with the router cutter or router, use a relevant sized auger bit in an electric drill to complete the operation.

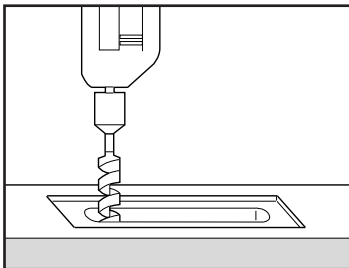

**Cutting Key and Spindle Holes** 

- Use a drill fitted with a suitable size drill bit to bore a hole for the spindle and the keyhole.
- Insert the lock body, test spindle and key actions then screw lock into place.
- To mark the frame to receive the striking plate, heavily mark the end of the lock bolt with a pencil. Close the door, open the lock bolt as far as it will go and gently move the door backwards and forwards.
- The pencil marks on the frame will indicate the position of the recess for the lock striking.

**TIP**

Before testing fit of the lock, engage the lock bolt in the locked position to enable the lock to be removed easily.

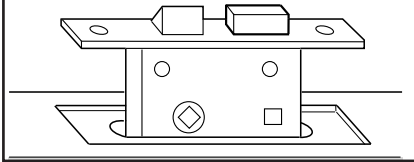

**MAINTENANCE**

Please use only Trend original spare parts and accessories.

The jig has been designed to operate over a long period of time with a minimum of maintenance. Continual satisfactory operation depends upon proper tool care and regular cleaning.

**Cleaning**

- Regularly clean the jig with a soft cloth.

**Lubrication**

- Your jig requires no additional lubrication.

**Storage**

- This jig should be stored in its packaging after use.
- An accessory case is also available Ref. CASE/DH.



**ENVIRONMENTAL PROTECTION**

Recycle raw materials instead of disposing as waste.

Packaging should be sorted for environmental-friendly recycling.

The product and its accessories at the end of their life should be sorted for environmental friendly recycling.

**GUARANTEE**

The jig carries a manufacturers guarantee in accordance with the conditions on the enclosed guarantee card.



Please use only Trend original spare parts.

<b>LOCK JIG - SPARE PARTS LIST</b>			<b>v4.0 07/2013 EB</b>
<b>No.</b>	<b>Qty.</b>	<b>Desc.</b>	<b>Ref.</b>
1	1	Lock Jig Body	WP-LOCK/01
2	1	Clamp Bar	WP-LOCK/02
3	6	Spacer Finger	WP-LOCK/03
4	2	Mini Knob 15mm Female M5 x 15mm	WP-LOCK/04
5	3	Adjustable Lever Female M8	WP-LOCK/05
6	2	Lobe Knob Male M10 x 40mm Tapped <07/02	WP-LOCK/06
6A	2	Lobe Knob Male M10 x 40mm Ball End >07/02	WP-LOCK/06A
7	3	Washer 8.5mm x 25mm x 1.5mm <07/02	WP-WASH/17
8	2	Plastic Cap 35mm Dia Black <07/02	WP-LOCK/08
8A	2	Plastic Cap Ball End >07/02	WP-LOCK/08A
9	2	Lobe Knob Foot <07/02	WP-LOCK/09
10	2	Machine Screw Csk M4 x 10mm Pozi <07/02	WP-SCW/69
11	2	Spring Washer M5	WP-WASH/29
12	1	Mortise Template A (34 x 97mm)	WP-LOCK/T/A
	1	Mortise Template B (34 x 132mm)	WP-LOCK/T/B
	1	Mortise Template C (37 x 104mm)	WP-LOCK/T/C
	1	Mortise Template D (37 x 134mm)	WP-LOCK/T/D
13	1	Face Plate Template 1 (40.4 x 174mm)	WP-LOCK/T/1
	1	Face Plate Template 2 (40.7 x 170.5mm)	WP-LOCK/T/2
	1	Face Plate Template 3 (43.6 x 139mm)	WP-LOCK/T/3
	1	Face Plate Template 4 (43.6 x 145mm)	WP-LOCK/T/4
	1	Face Plate Template 5 (43.6 x 151.5mm)	WP-LOCK/T/5
	1	Face Plate Template 6 (43.6 x 163mm)	WP-LOCK/T/6
	1	Face Plate Template 7 (43.6 x 171mm)	WP-LOCK/T/7
	1	Face Plate Template 8 (43.6 x 174mm)	WP-LOCK/T/8
	1	Face Plate Template 9 (43.6 x 183.5mm)	WP-LOCK/T/9
	1	Face Plate Template 10 (43.6 x 195mm)	WP-LOCK/T/10
	1	Face Plate Template 11 Latch	WP-LOCK/T/11
	1	Face Plate Template 12 (44.2 x 180mm)	WP-LOCK/T/12
14	1	Template Set (16pcs)	WP-LOCK/T/SET
15	1	Magnet 15mm x 3mm (4 Pack)	MAG/PACK/1
16	1	Guide Bush Collar 16mm to 30mm	GB/COLL/1630
17	1	Line up Template	WP-LOCK/T/LUP
18	1	Look-up Chart	LEAF/LC/LOCK
19	1	Manual	MANU/LOCK

**LOCK JIG - SPARE PARTS DIAGRAM**

v4.0 07/2013 EB

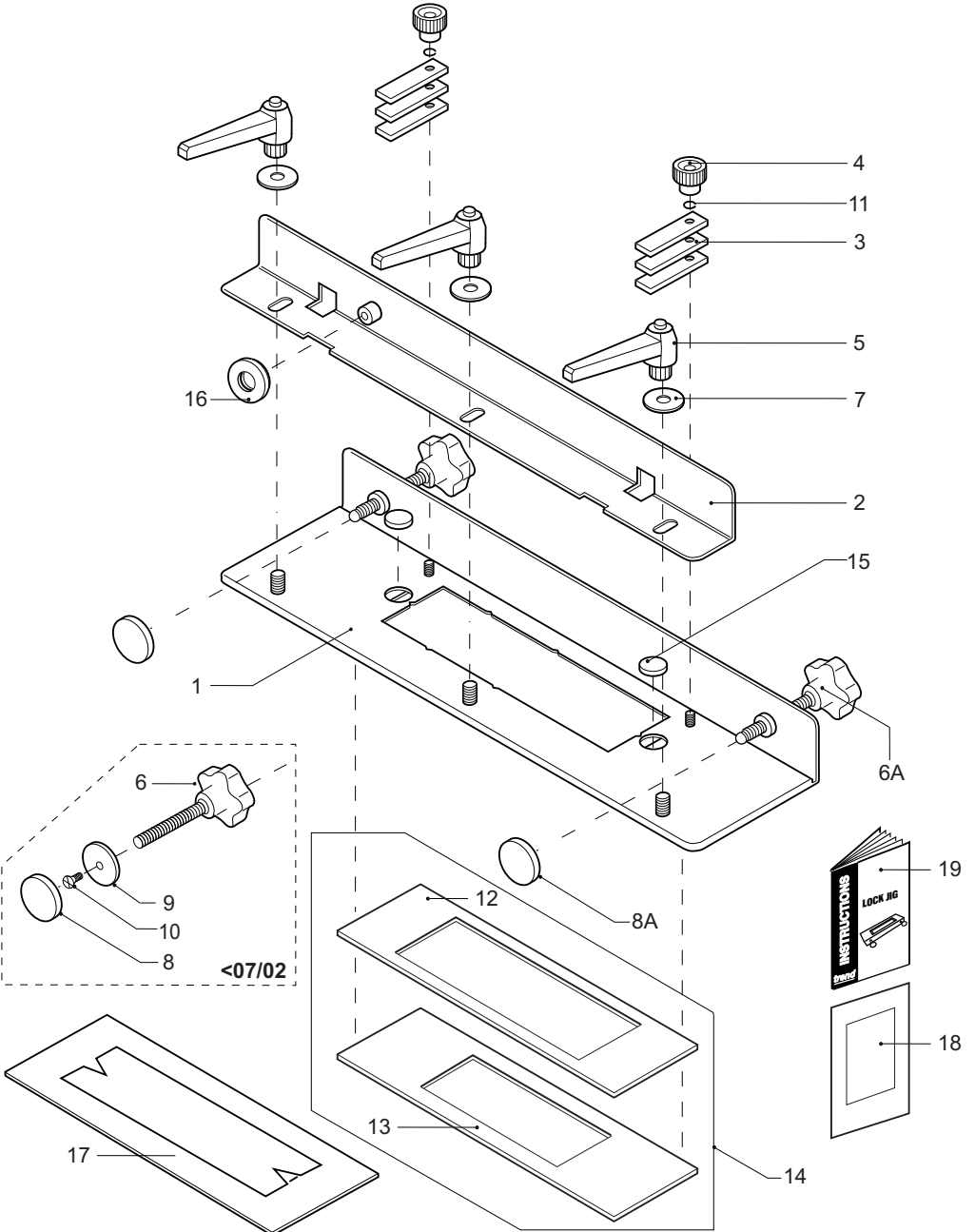

MANULOCK v9.1 (Batch EB)



**Trend Machinery & Cutting Tools Ltd.**  
Odhams Trading Estate St Albans Road  
Watford WD24 7TR England  
Tel: 0044(0)1923 249911  
technical@trendm.co.uk  
www.trend-uk.com