



# PRO POCKET HOLE JIG



**trend**<sup>®</sup>  
routing technology



Please read these instructions before use.

Dear Customer

Thank you for purchasing this Trend product, we hope you enjoy many years of creative and productive use.

Please remember to return your guarantee card within 28 days of purchase.

## CONTENTS

<b>TECHNICAL DATA</b> _____	<b>1</b>
<b>SAFETY PRECAUTIONS</b> _____	<b>2</b>
<b>ITEMS ENCLOSED</b> _____	<b>3</b>
<b>POCKET HOLE CONCEPT</b> _____	<b>3</b>
<b>DESCRIPTION OF PARTS</b> _____	<b>4</b>
<b>ASSEMBLY &amp; ADJUSTMENT</b>	
– Setting up the Jig _____	<b>5</b>
– Setting the Push-Pull Clamp _____	<b>5</b>
– Setting the Drill Bit Depth _____	<b>6</b>
<b>OPERATION</b>	
– Drilling the Pocket Holes _____	<b>7</b>
– Fitting the Dust Spout _____	<b>7</b>
– Assembling the Joint _____	<b>10</b>
<b>APPLICATIONS</b> _____	<b>11-13</b>
<b>ACCESSORIES</b> _____	<b>14</b>
<b>MAINTENANCE</b> _____	<b>15</b>
<b>ENVIRONMENTAL PROTECTION</b> _____	<b>15</b>
<b>GUARANTEE</b> _____	<b>15</b>
<b>PARTS</b>	
– Spare Parts List _____	<b>16</b>
– Spare Parts Diagram _____	<b>17</b>
<b>TROUBLE SHOOTING</b> _____	<b>18</b>

## TECHNICAL DATA

Material thickness:	Min.	12.7mm
	Max.	38mm
Material width:	Min.	38mm
Screw length:		25mm-63mm
Drill bit size		9.5mm
Hole pitch		30mm

The following symbols are used throughout this manual:



Denotes risk of personal injury, loss of life or damage to the tool in case of non-observance of the instructions in this manual.



Denotes risk of electric shock.



Refer to the instruction manual of your power tool.

This unit must not be put into service until it has been established that the power tool to be connected to this unit is in compliance with 2006/42/EC (identified by the CE marking on the power tool).

## INTENDED USE

This accessory is to be used with a drill with minimum 10mm chuck capacity to allow pocket hole jointing of softwoods and hardwoods.



If you require further safety advice, technical information or spare parts, please call Trend Technical Support or visit [www.trend-uk.com](http://www.trend-uk.com)

### SAFETY



#### WARNING:

Observe the safety regulations in the instruction manual of the power tool to be used. Please read the following instructions carefully. Failure to do so could lead to serious injury. When using electric tools, basic safety precautions, including the following should always be followed to reduce the risk of fire, electric shock and personal injury. Also observe any applicable additional safety rules. Read the following safety instructions before attempting to operate this product.

#### PLEASE KEEP THESE INSTRUCTIONS IN A SAFE PLACE.

The attention of UK users is drawn to The Provision and Use of Work Equipment Regulations 1998, and any subsequent amendments.

Users should also read the HSE/HSC Safe Use of Woodworking Machinery Approved Code of Practice and Guidance Document and any amendments.

Users must be competent before using our products.

#### IMPORTANT NOTE:

Residual Risk. Although the safety instructions and operating manuals for our tools contain extensive instructions on safe working with power tools, every power tool involves a certain residual risk which cannot be completely excluded by safety mechanisms. Power tools must therefore always be operated with caution!

#### General

1. Disconnect power tool when making any adjustments. When not in use, before servicing and when changing accessories such as cutters, disconnect power tool and attachment from power supply. Ensure the machine is switched off before plugging tool in or connecting to a power supply.
2. Always mount the power tool, accessory or attachment in conformity with the present instructions. The tool should not be modified or used for any application other than that for which it was designed.
3. Keep children and visitors away. Do not let children or visitors touch the tool, accessory or attachment. Keep children and visitors away from work area. Make the workshop child proof with padlock and master switch.
4. Dress properly. Do not wear loose clothing or jewellery, they can be caught in moving parts. Rubber gloves and non-skid footwear is recommended when working outdoors. Wear protective hair covering to contain long hair.

5. Consider working environment. Do not use the product in the rain or in a damp environment. Keep work area well lit. Do not use power tools near gasoline or flammable liquids. Keep workshop at a comfortable temperature so your hands are not cold. Connect machines that are used in the open via a residual current device (RCD) with an actuation current of 30 mA maximum. Use only extension cables that are approved for outdoor use.
6. The accessory or attachment must be kept level and stable at all times.
7. Keep work area clean. Cluttered workshops and benches can cause injuries. Ensure there is sufficient room to work safely.
8. Secure idle tools. When not in use, tools should be stored in a dry and high or locked up place, out of reach of children.
9. For best control and safety use both hands on the power tool and attachment. Keep both hands away from cutting area. Always wait for the spindle and cutter to stop rotating before making any adjustments.
10. Always keep guards in place and in good working order.
11. Remove any nails, staples and other metal parts from the workpiece.
12. Maintain tools and cutters with care. Keep cutters sharp and clean for better and safer performance. Do not use damaged cutters. Follow instructions for lubricating and changing accessories. Keep handles dry, clean and free from oil and grease.
13. Maintain accessories. Do not use damaged accessories. Only use accessories recommended by the manufacturer.
14. Check damaged parts. Before operation inspect the attachment, the power tool, the cable, extension cable and the plug carefully for signs of damage. Check for alignment of moving parts, binding, breakage, mounting and any other conditions that may effect its operation. Have any damage repaired by an Authorised Service Agent before using the tool or accessory. Protect tools from impact and shock.
15. Do not use tool if switch does not turn it on or off. Have defective switches replaced by an Authorised Service Agent.
16. Don't over reach. Keep proper footing and balance at all times. Do not use awkward or uncomfortable hand positions.
17. Don't abuse the cable. Never carry power tool or accessory by cord or pull it to disconnect from the socket. Keep cord from heat, oil and sharp edges. Always trail the power cord away from the work area.
18. Connect dust extraction equipment. If devices are provided for the connection of dust extraction and collection facilities, ensure these are connected and properly used.
19. Check all fixing and fastening nuts, bolts and screws on power tool, attachment and cutting tools before use to ensure they are tight and secure. Periodically check when machining over long periods.
20. Stay alert. Watch what you are doing. Use common sense. Do not operate tools when you are tired, under the influence of drugs or alcohol.
21. Personal Protective Equipment (PPE). All PPE must meet current UK and EU legislation.
22. Do not leave tools running unattended. Do not leave tool until it comes to a complete stop.
23. Always clamp workpiece being machined securely.
24. Only use cutting tools for woodworking that meet EN847-1/2 safety standards, and any subsequent amendments.
25. Vibration levels. Hand held power tools produce different vibration levels. You should always refer to the specifications and relevant Health & Safety Guide.
26. Use the attachment with the power tools and accessories specified in this manual only. Do not force the tool or attachment to do a job for which it is not designed.

Version 6.1 01/2014 PT1

**ITEMS ENCLOSED**

- 1 x Pro pocket hole jig
- 1 x Hex shank quick release stepped drill  
9.5mm (3/8") diameter HSS
- 1 x Depth collar for stepped drill
- 1 x Square drive screwdriver bit  
No.2 x 150mm long
- 100 x Self-tapping square head screws:
  - 10 x No.7 x 25mm (1") coarse
  - 30 x No.7 x 30mm (1 1/4") fine
  - 30 x No.7/8 x 30mm (1 1/4") coarse
  - 10 x No.8 x 37mm (1 1/2") coarse
  - 10 x No.8 x 50mm (2") coarse
  - 10 x No.8 x 63mm (2 1/2") coarse
- 1 x Hex key 3mm A/F
- 1 x Face clamp 75mm opening
- 2 x End stop/workpiece support blocks
- 2 x End stop/workpiece support rods
- 2 x End stop/workpiece support securing knobs
- 1 x Portable base adapter plate
- 1 x Drill depth turret stop
- 1 x Dust spout
- 2 x Dust spout fixing screws
- 1 x Manual
- 1 x Guarantee registration card

**POCKET HOLE CONCEPT**

A pocket hole involves placing one piece of the material to be joined in the jig and boring two counter-bored holes with a special stepped drill. This piece of material is joined to the other piece and assembled with self-tapping screws, which once driven into the material will provide a strong joint. The screw removes the need for clamping and the component can be handled whilst the glue is drying. The jig can be adjusted to suit different thicknesses of material to keep the screw centred in the workpiece to ensure a good joint.

**DESCRIPTION OF PARTS**

- (A) Pocket hole jig body
- (B) Guide block with solid hardened bushes
- (C) Solid bush drill guide hole
- (D) Guide block columns
- (E) Guide block workpiece thickness scale
- (F) Guide block column adjustment knobs
- (G) Material thickness side scale
- (H) Push-pull toggle clamp
- (I) Push-pull toggle clamp handle
- (J) Clamping pad
- (K) Adjustable clamping pad stud
- (L) Adjustable clamping pad lock nut
- (M) Push-pull secure machine screws
- (N) Bench fixing holes
- (O) Bench fixing screws
- (P) Hex shank quick release stepped drill
- (Q) Stepped drill depth collar
- (R) Hex key 3mm A/F
- (S) End stop/workpiece support blocks
- (T) End stop/workpiece support rods
- (U) End stop/workpiece adjustment knobs
- (V) Square drive self-tapping screw pack
- (W) Square drive screwdriver bit No.2 x 150mm
- (X) Portable base adapter plate
- (Y) Drill depth turret stop
- (Z) Dust spout
- (AA) Face clamp
- (AB) Carry bag

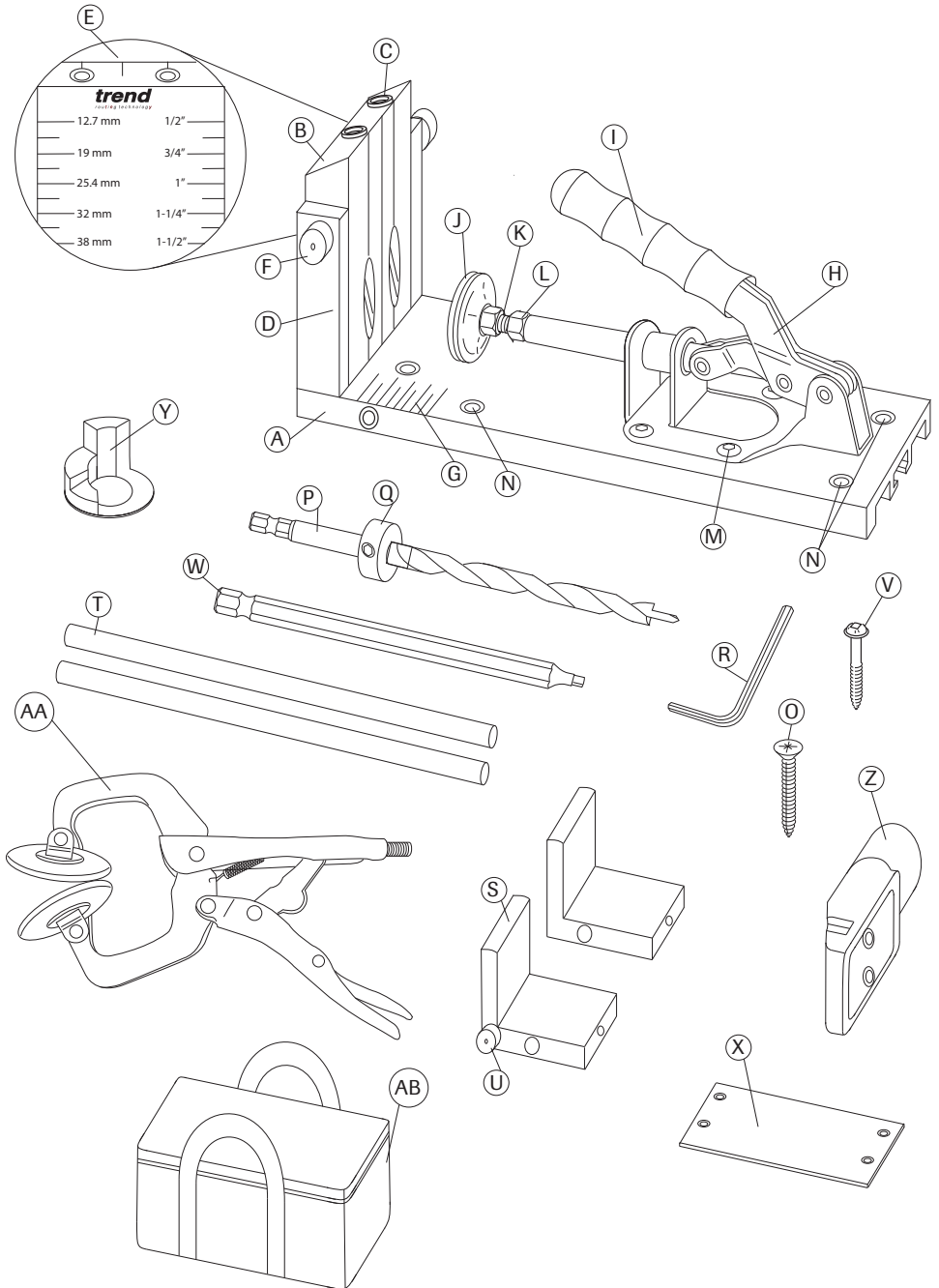

## ASSEMBLY & ADJUSTMENT

### Setting Up The Jig

The jig can be used both fixed to a bench or portable depending on the application. The most common position is screwed to a bench and the material clamped into the jig.

In the fixed bench position it is advisable to use the end stop/workpiece supports supplied to support the timber.

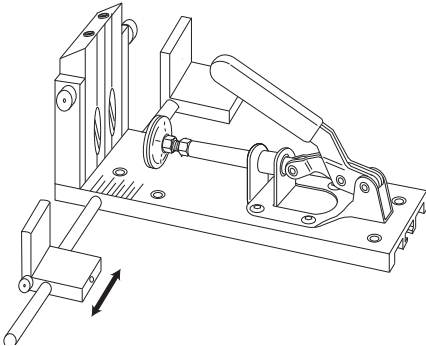

The built in push-pull clamp allows both hands to be free for drilling in both applications.

For portable use the jig can either be clamped to the actual component (see below) or the guide block and columns can be removed and clamped to the workpiece with the face clamp supplied.

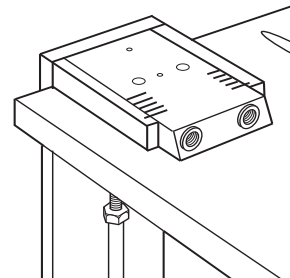

### Setting the Push-Pull Clamp

To bore the pocket holes you will need to set the clamp position to ensure it holds the material securely. The jig has a guide on the base to help set the clamp to the correct thickness of workpiece.

Rotate the threaded adjuster on the push-pull clamp until it is in the correct position. Tighten the clamping pad lock nut to secure the position.

If the workpiece moves when drilling the pocket apply more pressure with the clamp by screwing out the clamp pad further.

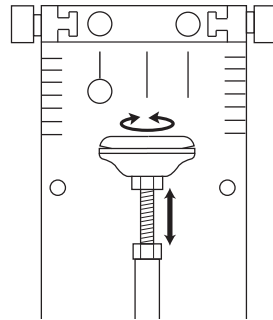

### Screw Chart

Fine Thread - For hardwoods eg oak, maple, walnut and cherry.

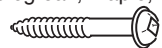

Coarse Thread - For softer timbers, plywood and particle board.

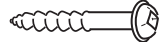

Timber Thickness	Screw Length
12.7mm (1/2")	25mm (1")
19mm (3/4")	30mm (1 1/4")
25.4mm (1")	37mm (1 1/2")
32mm (1 1/4")	50mm (2")
38mm (1 1/2")	63mm (2 1/2")

## Setting the Drill Bit Depth

The depth collar on the drill is used to control the depth of the pocket, which also sets the length of the screw that protrudes through and into the jointing piece. Place the drill depth turret stop in the hole.

Loosen the drill depth thickness adjustment knobs on the guide columns and lift the guide block until the lines on the columns are aligned with the desired workpiece thickness as shown on the guide block scale.

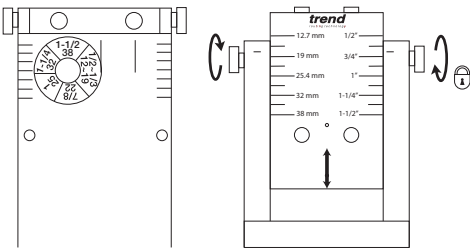

Turn the depth turret stop until the desired size is at the bottom of the bush.

Put the stepped drill into the bushed hole in the column. The drill tip should be touching the depth turret stop.

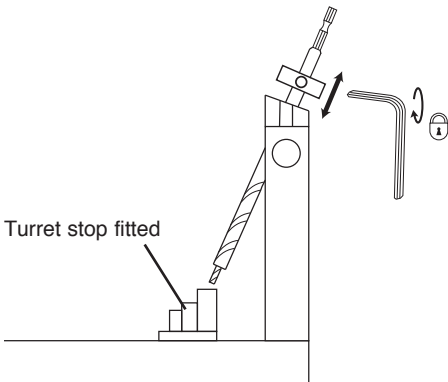

Loosen the collar grub screw using the 2.5mm A/F hex key and place onto the shank of the drill. Push it down the shank until it touches the top of the bush. Tighten the grub screw securely. The collar is now set for your desired workpiece thickness.

Check the collar position is correct before drilling to drill. If the depth collar is set too deep the screw may protrude through the face of the jointing piece. If too shallow the screw may not enter into the joint sufficiently. When working with thin material and mitres, the counterbored hole will need to be shallower than standard.

Shallow counterbored holes will result in the head of the screw being closer to or above the surface, this is acceptable in certain applications where the head of the screw is invisible from view.

Turn the depth turret stop until the desired size is at the bottom of the bush. Put the stepped drill into the bushed hole in the column. The drill tip should be touching the depth turret stop.

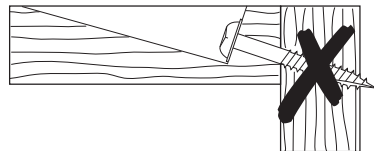
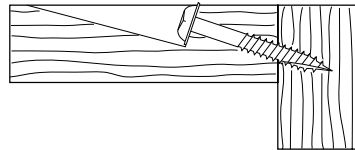

**Before using the pocket hole jig for the first time, it is recommended that a number of trial cuts are made in waste timber as this will allow the drill to bed into the drill guide bushes in the columns. During the bedding in process there will be evidence of some metal swarf.**

**OPERATION**



**Pocket Hole Spacing**

When boring framing material, two pocket holes should be used to keep the timber from twisting. When working with long pieces of timber to create a board (jointing edge to edge) to make a table top for example, single pockets can be drilled at between 150mm and 200mm centres.

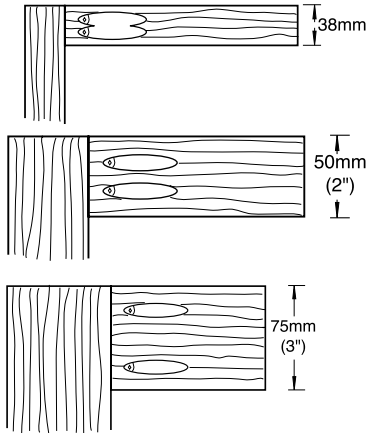

**Fitting the Dust Spout**

Before starting the drilling operation it is advised to fit the supplied dust spout onto the drill guide block. This will reduce the amount of dust in your work area and will help keep the jig and accessories clean and dust free.

To fit the dust spout place it against the back of the drill guide block, lining up the corresponding fixing holes. Insert the dust spout fixing screws and tighten using the 3mm A/F hex key.

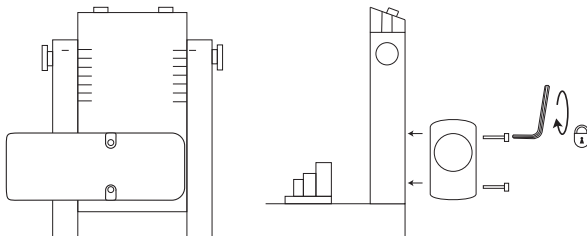

**Using the Portable Base**

The Adjustable pocket hole jig can be turned into a portable jig by removing the drill guide block and guide columns, then attaching the portable base plate.

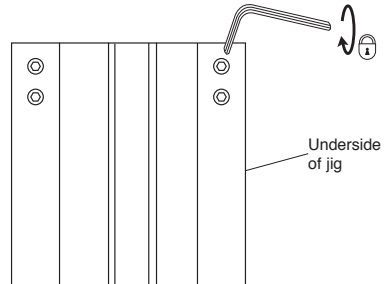

To remove the guide columns undo the guide column fixing screws.

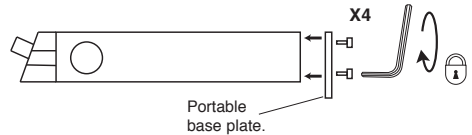

Attach the portable base plate to the columns using the fixing screws. Use the scale to set the right material thickness. Once set, tighten the column adjustment knobs.



### Using the Stabilising Bars

The stabilising bars and supports/end stops can be used to stabilise the workpiece or to hold the workpiece in place.

For stabilising use insert the bar through the hole in the side of the jig as shown below.

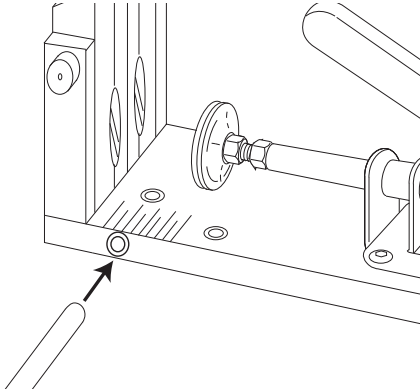

Push the support/end stop on from the other end of the bar through the hole in the side of the support.

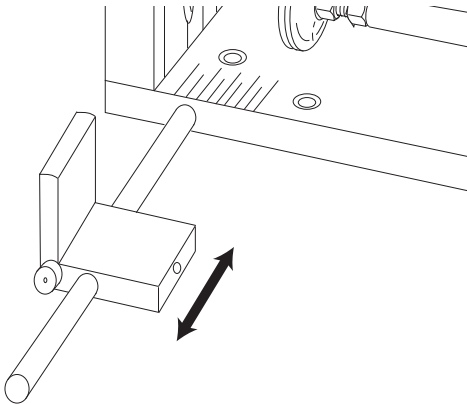

Repeat for the other side.

Place your workpiece onto the jig and adjust the supports into the best position.

For use as end stops insert the bar into the hole in the side of the jig as shown across the page. Push the end stops on to the bar through the hole in the front as shown below.

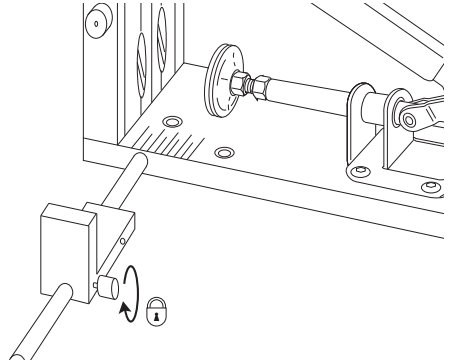

Place your workpiece onto the jig and adjust the end stops into position at the ends of the workpiece.

Tighten the adjustment knobs to hold the end stops in place.

Repeat for the other side.



**The stabilising bars can also be locked in position in end stop mode.**

## **Drilling the Pocket Holes**



Boring the counter-bored hole involves drilling with a stepped drill into one of the joint pieces.

Fit the material to be drilled into the jig and clamp tightly.

Make sure the component is clamped securely before drilling.

Fit the drill bit with the depth collar already set it to the chuck of the drill used.

Place drill bit into top section of the bush hole in drill guide. Do not place the drill tip against the component.

Switch on drill at full speed (clockwise direction) and drill into the component until the collar touches the bush. Gently pulling drill in and out whilst drilling will allow wood chips to clear more easily.

Once depth is reached switch off drill and withdraw drill bit from guide.

Repeat for other pocket hole and then remove component.

Repeat operation for remaining pieces.



**Do not push hard on the drill until the drill pilot tip of the drill bit is fully into the work piece and the counterbore section is actually cutting.**



**Use a high drilling speed to increase drill life (2000 rpm or higher).**



**Keep the drill bit sharp.**



**Make sure drill bit is held in chuck securely. If the drill spins loose in the chuck the shock can break the drill bit tip.**



**Place the drill bit into the top section of the drill guide hole before spinning. Do not place the drill tip against the component until the drill is at full speed.**

## Assembling the Joint



Self-tapping pocket hole screws do not need to have pilot holes drilled, even in hardwoods. Other types of screws can work in the jig but the self-tapping screws reduce splitting in the timber and are hardened to reduce breakage. Whenever possible use glue on the joint unless it is necessary to disassemble the joint.

To aid assembly on corner joints, it is advisable to use a high batten, clamped to the bench. The components can be pushed against it to keep the two parts flush to each other, whilst screwing them together.

When assembling edge to edge joints it is advisable to use the face clamp to keep both parts flush. The face clamp can be adjusted to suit material thickness by adjusting the locking nut on the handle of the face clamp. The larger pad on the face should be on the face side of the material.

The screw should be driven into the component using a torque control screwdriving drill. The torque control allows control of the tightness of the screws into the wood and minimise the possibility of stripping the screw. The screwdriver bit has a 1/4" quick change shank and can be used directly into a drill chuck or more conveniently into a Trend Snappy quick change drill chuck Ref. SNAP/QC.

If a torque control screwdriver is not available start to screw with a conventional drill and then finish off by hand using a square drive hand screwdriver or the Trend Snappy Hand driver Ref. SNAP/HAND/1.

If access to the screws are tight the screwdriver bits can be fitted into a 1/4" socket fitted to a ratchet or use a flexible shaft screwdriver.

After use, store jig carefully.

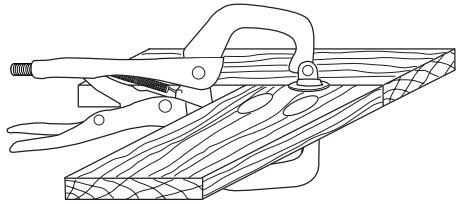
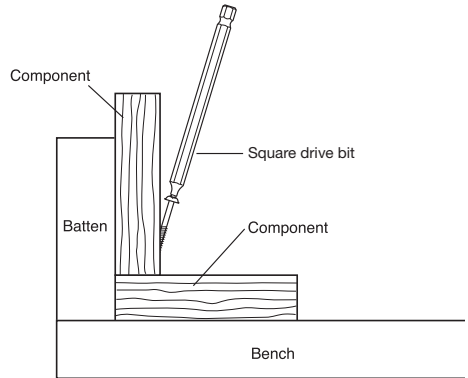

**APPLICATIONS**

**Frame Corner Joints** – faster and stronger than dowel and biscuits. Self clamping whilst glue is drying.

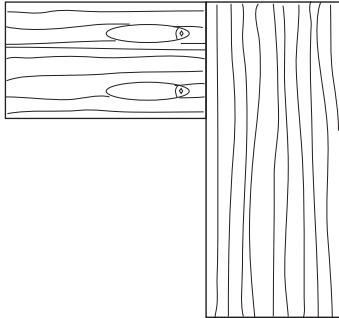

**Square Corner Joints** – faster and stronger than dowel and biscuits. Self clamping whilst glue is drying.

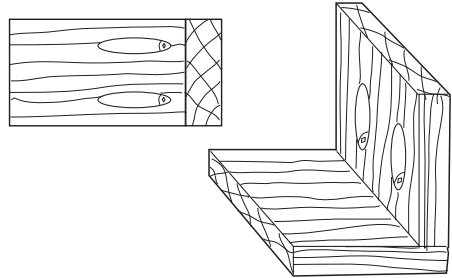

**Mitred Frame Corner Joints** – for narrow frames a single pocket hole is necessary. Cut the mitre and rout any rebates before boring the pocket holes. For material less than 50mm wide it may be necessary to tilt the pocket hole piece so that the hole is not perpendicular to the mitred edge.

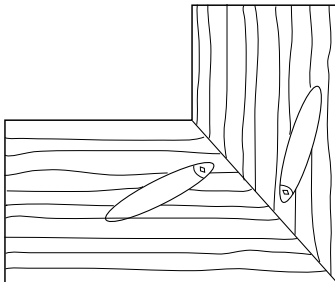

**T- Joints** – faster and stronger than dowel and biscuits. Self clamping whilst glue is drying.

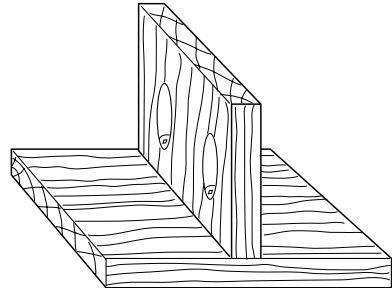

**When changing material or joint application, test the depth of the drill and collar before drilling into the workpiece. Test drill in waste pieces of the same thickness. Then drill a screw into the pocket joint only and lay it against the jointing piece to see if screw depth is correct.**

**Angled Joints** – eliminates difficult clamping up. The joint is created not by cutting each mitre to half the angle but by cutting angle on one joining piece and drilling pocket holes into the square piece. The method results in the mitred edge having an overhang, which will need to be removed by plane or sander.

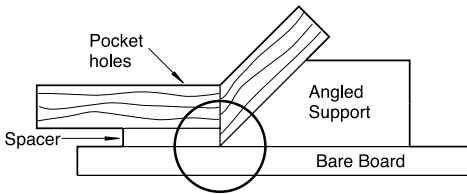
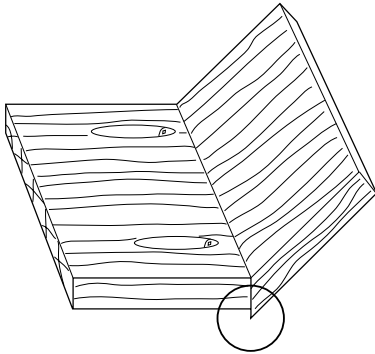
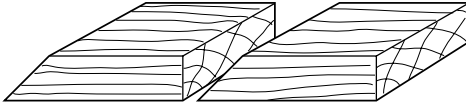

**Curved Joints** – this uses the same technique as the angled joint, but the angles will be shallower ( $5^{\circ}$  to  $15^{\circ}$ ). The overhang will need to be removed as previous.

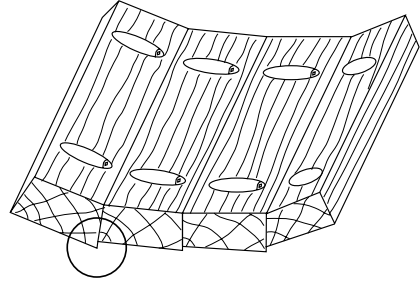

**Mitred Corner Joints** – joining two pieces with  $45^{\circ}$  mitres with the pocket jig is not advisable, however a  $90^{\circ}$  change of direction can be created by using a bevel-jointing piece. The joint comprises of a  $90^{\circ}$  infill piece with  $45^{\circ}$  mitres on both sides.

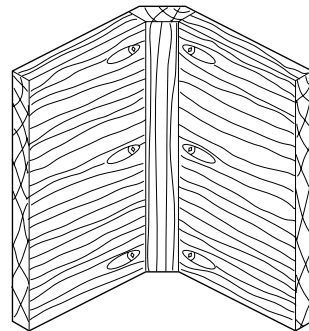
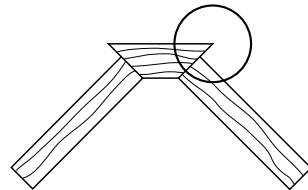

**Plinths** – faster and stronger than dowel and biscuits.

**Edge to Edge Joints** – allows narrow strips to be jointed to create wider boards such as a table top.

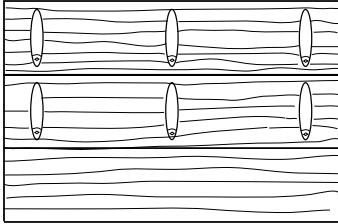

**Post and Rail Joints** – pocket holes allow strong table and chair joints. For fitting table tops to rails, the rails will need to be pocket hole drilled. To allow for the movement of the timber as it expands and contracts the hole must be slightly over size. This is achieved by lifting the rail about 3mm off the base of the jig. This should allow the pilot tip of the drill to break through the end of the timber, giving the screw space for some movement. Alternatively move the rail sideways slightly to drill another pocket hole (interlocking) allowing a slot for the screw.

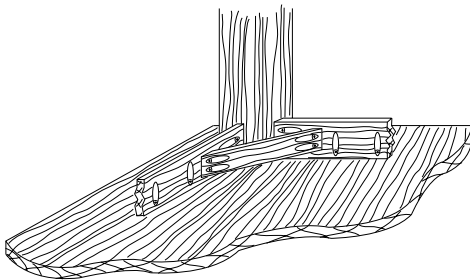

**Edging of countertops or shelving** – quick and easy way to join edging onto plywood, MDF or Particle board shelves.

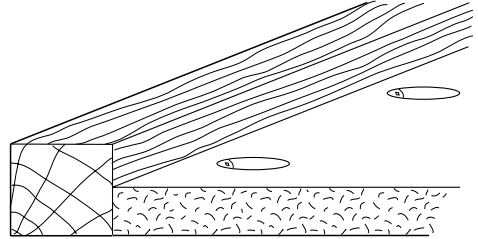

**Jig making** – very useful for jig making and temporary assembly operations. Ideal for routing jigs.

**Framed Panel (Cabinet) Joints** – pocket holes can be used for almost all framed cabinet carcass construction.

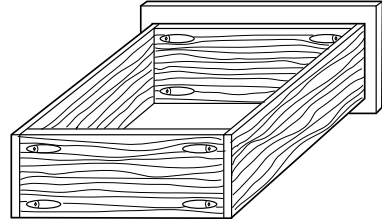

## ACCESSORIES

Please use only Trend original accessories.

### Self Tapping Screws Square Drive Fine Thread

No.6 (3.4mm) x 25mm (1"). Pack 500.  
Ref. PH/6X25/500

No.7 (3.6mm) x 30mm (1¼"). Pack 500.  
Ref. PH/7X30/500

### Self Tapping Screws Square Drive Coarse Thread

No.7 (3.6mm) x 25mm (1"). Pack 500.  
Ref. PH/7X25/500C

No.7/8 (4.3mm) x 30mm (1"). Pack 500.  
Ref. PH/7X30/500C

No.8 (4.3mm) x 37mm (1½"). Pack 200.  
Ref. PH/8X37/200C

No.8 (4.3mm) x 50mm (2"). Pack 200.  
Ref. PH/8X50/200C

No.8 (4.3mm) x 63mm (2½"). Pack 200.  
Ref. PH/8X63/200C

### Pocket Hole Screws Mixed Box 850pcs

#### Fine Thread

No.6 x 25mm (200pcs)  
No.7 x 25mm (100pcs)

#### Coarse Thread

No.7 x 25mm (200pcs)  
No.7/8 x 30mm (125pcs)  
No.8 x 37mm (75pcs)  
No.8 x 50mm (75pcs)  
No.8 x 63mm (75pcs)

Ref. PH/SCW/PK1

### Pocket Hole Drills

Standard Parallel Shank.  
Ref. PH/DRILL/95

178mm Quick Change - for deeper pockets.  
Ref. PH/DRILL/95Q

### Pocket Hole Plug Cutter

A tool steel pellet cutter that is used in a pillar drill to allow plugs to be made to cover the pocket hole. Allows plugs up to 52mm long to be created in end grain.  
Ref. PH/PC/95

## MAINTENANCE



Please use only Trend original spare parts and accessories.

The accessory has been designed to operate over a long period of time with minimum of maintenance. Continual satisfactory operation depends upon proper tool care and regular cleaning.

### Cleaning

- Keep the threads and clamp mechanism clear of sawdust and resin build-up.
- Regularly clean with a soft cloth.

### Lubrication

- Periodically lubricate the holes in the guide columns with PTFE dry lubricant.

### Drill Bit Care

- Ensure the drill bit is sharp.
- Check tightness of depth collar set screw.

### Storage

- After use store jig in its packaging or in a cupboard.

## ENVIRONMENTAL PROTECTION

### Recycle raw materials instead of disposing as waste.

Packaging should be sorted for environmental-friendly recycling.

The product and its accessories at the end of its life should be sorted for environmental-friendly recycling.

## GUARANTEE

All Trend products are guaranteed against any defects in either workmanship or material, except products that have been damaged due to improper user or maintenance.

Please use only Trend original spare parts.

<b>PH/JIG/AK - SPARE PARTS LIST</b>			<b>v1.0 08/2018</b>
<b>No.</b>	<b>Qty.</b>	<b>Desc.</b>	<b>Ref.</b>
1	1	Jig Base	WP-PHJA/01
2	1	Guide Block with Solid Bushes	WP-PHJA/02
3	1	Drill Depth Turret	WP-PHJA/03
4	2	Guide Block Column	WP-PHJA/04
5	2	Guide Block Column Adjustment Knobs	WP-PHJA/05
6	1	Push-pull Clamp Complete	WP-PHJA/06
7	1	Push-pull Clamp Adjustable Pad & Stud Assembly	WP-PHJA/07
8	4	Machine Screw Dome M5 x 10mm Socket	WP-SCW/71
9	1	Hex Shank Quick Release Stepped Drill Bit Short	PH/DRILL/95QS
10	1	Depth Collar for Stepped Drill	PH/COLL/95
11	1	Square Drive Screwdriver Bit No.2 x 150mm Long	SNAP/SQ/2B
12	1	Dust Spout Elbow	WP-PHJA/08
13	2	Dust Spout Fixing Screws	WP-PHJA/09
14	4	Hex Screw Cap M4 x 15mm Skt	WP-SCW/131
15	2	Hex Screw Cap M4 x 40mm Skt	WP-SCW/
16	2	T-Bolt M4 x 18mm	WP-PHJA/10
17	2	Stabilising Bar (Stainless Steel)	WP-PHJA/11
18	1	Support/End Stop Block (Pair)	WP-PHJA/12
19	1	Portable Base Adapter Plate	WP-PHJA/13
20	1	Hex Key 3mm A/F	WP-AP/03
21	10	Self-tapping Screw No.7 x 25mm (Course)	PH/7X25/500C
22	30	Self-tapping Screw No.7 x 30mm (Fine)	PH/7X30/500
23	30	Self-tapping Screw No.7/8 x 30mm (Coarse)	PH/7X30/500C
24	10	Self-tapping Screw No.8 x 37mm (Coarse)	PH/8X37/200C
25	10	Self-tapping Screw No.8 x 50mm (Coarse)	PH/8X50/200C
26	10	Self-tapping Screw No.8 x 63mm (Coarse)	PH/8X63/200C
27	4	Bench Fixing Screw Csk No.8 x 25mm Pozi	WP-SCW/100
28	1	Face Clamp 260mm Long x 75mm Throat x 75mm Opening	PH/CLAMP/F10
29	1	Nylon Carry Bag	CASE/PHJ/A
30	1	Manual	MAN/PH/AK



**PH/JIG/AK - SPARE PARTS DIAGRAM**

**v1.0 08/2018**

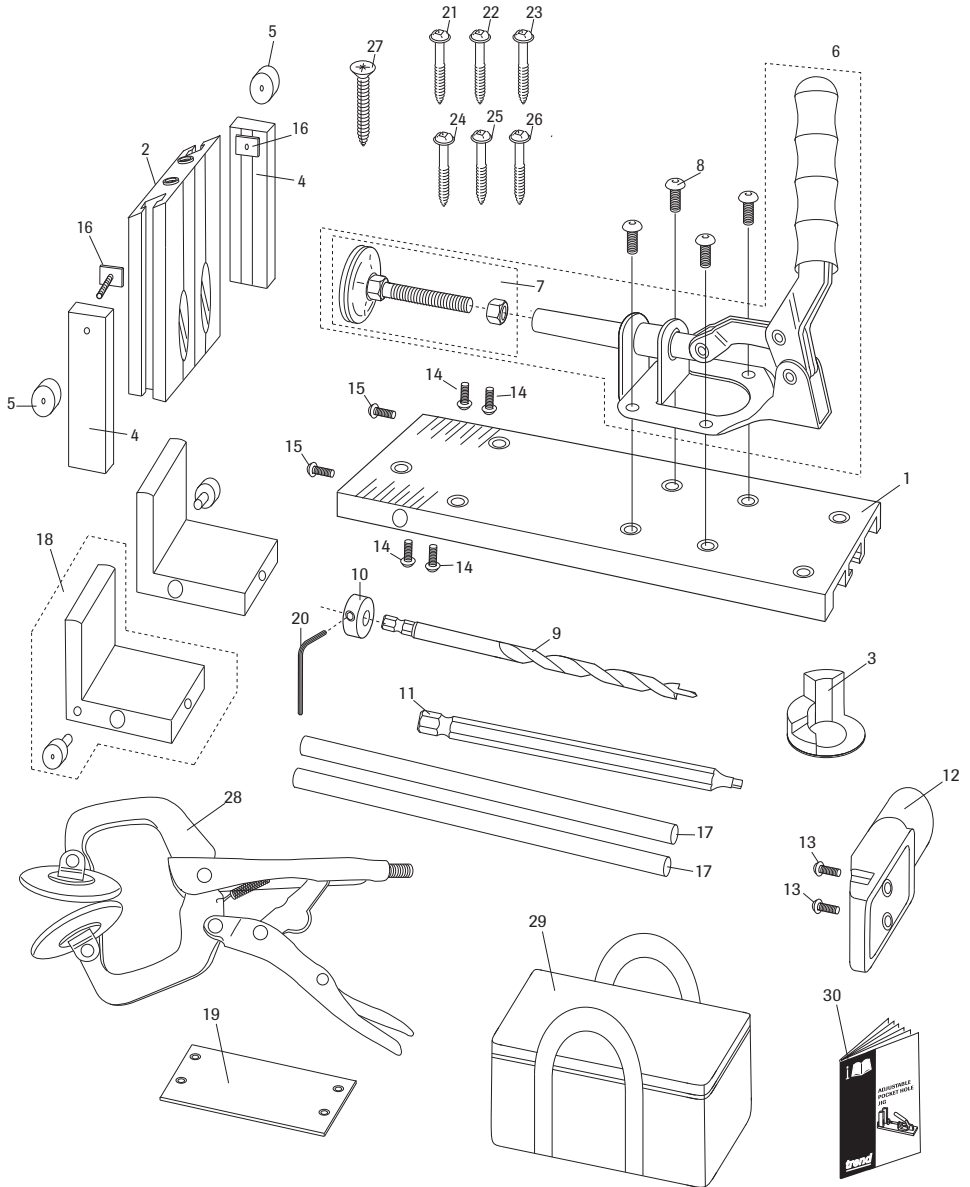

**TROUBLE SHOOTING**

<b>Fault</b>	<b>Cause</b>	<b>Remedy</b>
■ Drill guide columns move when drilling.	Fixing screw not tight.	Tighten fixing screw with hex.
■ Screw protrudes through face of mating piece.	Depth collar set too high causing drill bit to drill too deep.	Adjust height of collar on drill bit.
■ Workpieces will not pull together tightly when being assembled.	Occur on very hard woods, when thread of self-tapping screws are holding on both pieces of material and pushing them apart.	Clamp material more tightly or adjust collar so drill point nearly breaks through first piece of material.
■ Workpieces do not sit flush or move when being assembled.	Screws tend to follow grain of the wood.	Clamp more securely to prevent material movement when assembling. Use face clamp for edge to edge joints.

MANU/PH/AK V1.0



RECYCLABLE

**Trend Machinery & Cutting Tools Ltd.**

Odhams Trading Estate St Albans Road  
Watford WD24 7TR England

**Tel: 0044(0)1923 249911**

**technical@trendm.co.uk**

**www.trend-uk.com**