



PH/JIG/M



trend[®]
routing technology



Please read these instructions before use.

Dear Customer

Thank you for purchasing this Trend product, we hope you enjoy many years of creative and productive use.

Please remember to return your guarantee card within 28 days of purchase.

CONTENTS

TECHNICAL DATA	1
SAFETY PRECAUTIONS	2
POCKET HOLE CONCEPT	3
ITEMS ENCLOSED	3
DESCRIPTION OF PARTS	4
ASSEMBLY & ADJUSTMENT	
– Setting the Long or Short Base	5
– Fitting Long Base	5
– Fitting Short Base	5
– Setting Pocket Hole Centres	5
– Clamping	5
– Setting the Drill Bit Depth	6
OPERATION	
– Material Thickness	7
– Pocket Hole Spacing	8
– Drilling the Pocket Holes	8
– Assembling the Joint	9
APPLICATIONS	10-12
ACCESSORIES	13
MAINTENANCE	13
ENVIRONMENTAL PROTECTION	13
GUARANTEE	13
SPARE PARTS	
– Spare Parts List	14
– Spare Parts Diagram	15
TROUBLE SHOOTING	16

TECHNICAL DATA

Material thickness:	Min.	16mm
	Max.	38mm
Material width:	Min	38mm
Drill bit size		9.5mm
Hole pitch		18-54mm

The following symbols are used throughout this manual:



Denotes risk of personal injury, loss of life or damage to the tool in case of non-observance of the instructions in this manual.



Denotes risk of electric shock.



Refer to the instruction manual of your power tool.

This unit must not be put into service until it has been established that the power tool to be connected to this unit is in compliance with 2006/42/EC (identified by the CE marking on the power tool).

INTENDED USE

This accessory is to be used with a drill with minimum 10mm chuck capacity to allow pocket hole jointing of softwoods and hardwoods. It is ideally suited for use with materials 19mm thick.



If you require further safety advice, technical information or spare parts, please call Trend Technical Support or visit www.trend-uk.com

SAFETY



WARNING:

Observe the safety regulations in the instruction manual of the power tool to be used. Please read the following instructions carefully. Failure to do so could lead to serious injury. When using electric tools, basic safety precautions, including the following should always be followed to reduce the risk of fire, electric shock and personal injury. Also observe any applicable additional safety rules. Read the following safety instructions before attempting to operate this product.

PLEASE KEEP THESE INSTRUCTIONS IN A SAFE PLACE.

The attention of UK users is drawn to The Provision and Use of Work Equipment Regulations 1998, and any subsequent amendments.

Users should also read the HSE/HSC Safe Use of Woodworking Machinery Approved Code of Practice and Guidance Document and any amendments.

Users must be competent before using our products.

IMPORTANT NOTE:

Residual Risk. Although the safety instructions and operating manuals for our tools contain extensive instructions on safe working with power tools, every power tool involves a certain residual risk which cannot be completely excluded by safety mechanisms. Power tools must therefore always be operated with caution!

General

1. Disconnect power tool when making any adjustments. When not in use, before servicing and when changing accessories such as cutters, disconnect power tool and attachment from power supply. Ensure the machine is switched off before plugging tool in or connecting to a power supply.
2. Always mount the power tool, accessory or attachment in conformity with the present instructions. The tool should not be modified or used for any application other than that for which it was designed.
3. Keep children and visitors away. Do not let children or visitors touch the tool, accessory or attachment. Keep children and visitors away from work area. Make the workshop child proof with padlock and master switch.
4. Dress properly. Do not wear loose clothing or jewellery, they can be caught in moving parts. Rubber gloves and non-skid footwear is recommended when working outdoors. Wear protective hair covering to contain long hair.
5. Consider working environment. Do not use the product in the rain or in a damp environment. Keep work area well lit. Do not use power tools near gasoline or flammable liquids. Keep workshop at a comfortable temperature so your hands are not cold. Connect machines that are used in the open via a residual current device (RCD) with an actuation current of 30 mA maximum. Use only extension cables that are approved for outdoor use.
6. The accessory or attachment must be kept level and stable at all times.
7. Keep work area clean. Cluttered workshops and benches can cause injuries. Ensure there is sufficient room to work safely.
8. Secure idle tools. When not in use, tools should be stored in a dry and high or locked up place, out of reach of children.
9. For best control and safety use both hands on the power tool and attachment. Keep both hands away from cutting area. Always wait for the spindle and cutter to stop rotating before making any adjustments.
10. Always keep guards in place and in good working order.
11. Remove any nails, staples and other metal parts from the workpiece.
12. Maintain tools and cutters with care. Keep cutters sharp and clean for better and safer performance. Do not use damaged cutters. Follow instructions for lubricating and changing accessories. Keep handles dry, clean and free from oil and grease.
13. Maintain accessories. Do not use damaged accessories. Only use accessories recommended by the manufacturer.
14. Check damaged parts. Before operation inspect the attachment, the power tool, the cable, extension cable and the plug carefully for signs of damage. Check for alignment of moving parts, binding, breakage, mounting and any other conditions that may effect its operation. Have any damage repaired by an Authorised Service Agent before using the tool or accessory. Protect tools from impact and shock.
15. Do not use tool if switch does not turn it on or off. Have defective switches replaced by an Authorised Service Agent.
16. Don't over reach. Keep proper footing and balance at all times. Do not use awkward or uncomfortable hand positions.
17. Don't abuse the cable. Never carry power tool or accessory by cord or pull it to disconnect from the socket. Keep cord from heat, oil and sharp edges. Always trail the power cord away from the work area.
18. Connect dust extraction equipment. If devices are provided for the connection of dust extraction and collection facilities, ensure these are connected and properly used.
19. Check all fixing and fastening nuts, bolts and screws on power tool, attachment and cutting tools before use to ensure they are tight and secure. Periodically check when machining over long periods.
20. Stay alert. Watch what you are doing. Use common sense. Do not operate tools when you are tired, under the influence of drugs or alcohol.
21. Personal Protective Equipment (PPE). All PPE must meet current UK and EU legislation.
22. Do not leave tools running unattended. Do not leave tool until it comes to a complete stop.
23. Always clamp workpiece being machined securely.
24. Only use cutting tools for woodworking that meet EN847-1/2 safety standards, and any subsequent amendments.
25. Vibration levels. Hand held power tools produce different vibration levels. You should always refer to the specifications and relevant Health & Safety Guide.
26. Use the attachment with the power tools and accessories specified in this manual only. Do not force the tool or attachment to do a job for which it is not designed.

Version 6.1 01/2014 PT1

POCKET HOLE CONCEPT

A pocket hole concept involves clamping a pocket hole jig to one piece of the material to be joined in the jig and boring two counter-bored holes with a special stepped drill. This piece of material is joined to the other piece and assembled with 30mm long self-tapping screws, which once driven into the material will provide a strong joint.

No pilot hole is required, but wood glue should be used to provide a strong long lasting joint. The screw removes the need for clamping and the component can be handled whilst the glue is drying.

It is ideally suited for use with 19mm (3/4") thick material because the distance from the base of the jig to the drill guide, combined with the angle of the screws, causes the screw to exit the 19mm material at its centre.

An accessory stepped drill bit with collar Ref. SNAP/PHD/95 is available with a 1/4" hex quick-change fitting, which allows faster tool change.

ITEMS ENCLOSED

- 1 x Mini Pocket Hole Jig with long base and columns
- 1 x Short base
- 1 x Stepped drill 9.5mm (3/8") diameter x 150mm long HSS
- 1 x Depth collar for stepped drill
- 1 x Square drive screwdriver bit No.2 x 150mm long
- 50 x Self-tapping square head screws No.7 x 30mm
- 1 x Hex key 4mm A/F
- 1 x Hex Key 2.5mm A/F
- 1 x Manual
- 1 x Guarantee registration card

ITEMS REQUIRED

- Drill with minimum 10mm chuck.
- Hand tools.
- Clamps.

DESCRIPTION OF PARTS

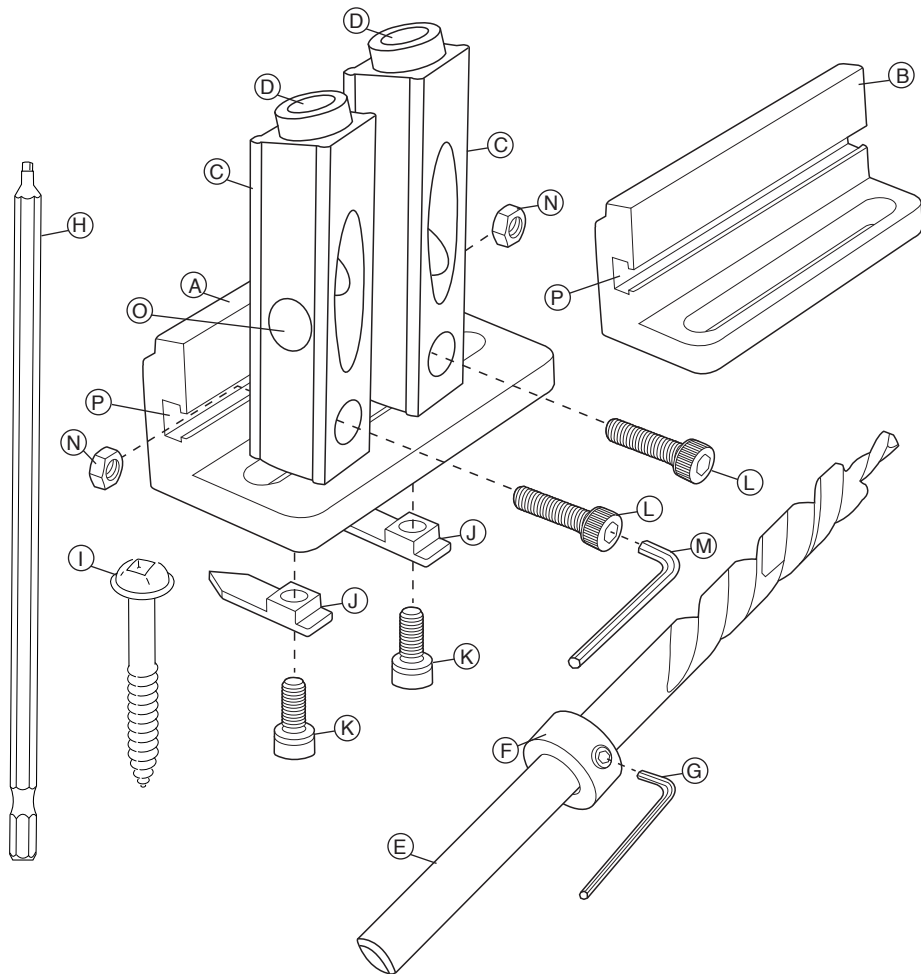

- (A) Jig base
- (B) Short (flush base)
- (C) Guide columns with solid bushes
- (D) Solid bush drill guide hole
- (E) Stepped drill
- (F) Stepped drill depth collar
- (G) Depth collar hex key 2.5mm A/F
- (H) Long square drive screwdriver bit No.2 x 150mm long for self-tapping screws

- (I) Square drive self-tapping screw
- (J) Scale marker
- (K) Scale marker fixing screw
- (L) Guide column locking screw
- (M) Guide column locking screw hex key 4mm A/F
- (N) Guide column locking screw nut
- (O) Wood waste clearance hole
- (P) Base T-Slot

ASSEMBLY & ADJUSTMENT

Setting up the Long or Short Base

The jig is supplied with two bases long and short. The long base has a built in stop and is used for standard pocket hole joining, whereas the short base is flush and allows the jig to be set to suit certain material thicknesses and for repair work.

Fitting the Long Base

Fit the guide columns to the long base using two M5 guide column locking screws and two M5 nuts. Place the machine screws through the column holes and loosely thread the nuts onto the machine screws. Ensuring the wood waste clearance holes in the columns point away from each other, slide the nut and assembly into the T-slot in the long base, and tighten slightly with the 4mm A/F hex key. Fit the scale marker using the scale marker fixing screws into the base of the guide columns and loosely tighten with the 4mm A/F hex key, ensuring the guide columns can still slide.

Fitting the Short Base



Fit the guide columns to the short base using two M5 guide column locking screws and two M5 nuts. Place the machine screws through the column holes and loosely thread the nuts onto the machine screws. Ensuring the wood waste clearance holes in the columns point away from each other, slide the nut and assembly into the T-slot in the short base, and tighten slightly with the 4mm A/F hex key. The short base for some applications will not need the scale markers to be fitted.

Setting Pocket Hole Centres

The mini pocket hole jig has variable distance drill guide columns to allow material of min. width of 38mm (1-1/2") to be joined.

The adjustable guides can be locked at various positions allowing hole centres of 18mm to 54mm per set up.

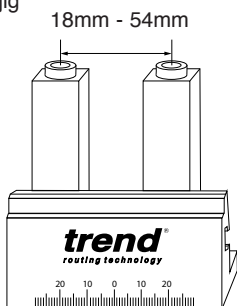

The jig has scale markers that screw into the underside of the guide columns and can be used to position the guide columns to a scale on the bases. The scale markers are used with both the long and short bases. The scale markers also provide secondary fixing for the guide columns.

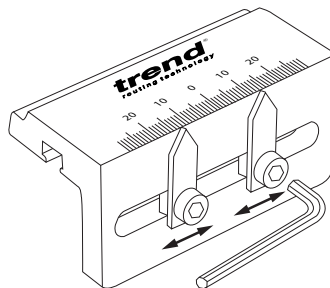

For some applications with the short base the scale markers are not used.

Using the scale markers position the guide columns to the scale, to set the width centres.

Once the guide columns are in the correct position, gently tighten the scale marker screws (do not over tighten). Lock the guide columns in the position using the guide column locking screws and a 4mm A/F hex key. Ensuring guide columns are upright.

Clamping



The jig must be clamped securely when drilling. The jig and component can be clamped together to a workbench using suitable clamp(s).

The clamp should be placed on the base if access allows, alternatively the guide columns could be clamped.



Ensure work position is comfortable, keep proper footing at all times. Consider working environment before using tools.



Ensure component is held securely to a workbench and placed at a suitable and comfortable work height.

Setting the Drill Bit Depth

The depth collar on the drill is used to control the depth of the pocket, which also sets the length of the screw that protrudes through and into the joining piece.

- To set the depth collar on the stepped drill, loosen the collar set screw using the 2.5mm A/F hex key and place onto the shank of the drill about 50mm down.
- Lightly tighten the set screw to lock the collar onto the drill.
- Put the stepped drill with collar fitted into the bushed hole in the column, which is fitted to the long base, until the collar touches the top of the bush.
- Gently loosen the set screw on the collar and adjust the depth of the drill so that the end of the drill tip is about 3mm above the base (a packing piece or coin can be used).
- Tighten the set screw securely. The collar is now set for 30mm long screws and for timber 16mm to 22mm thick. This gives approximately half of the screw into each workpiece.
- Check collar position is correct before beginning to drill.

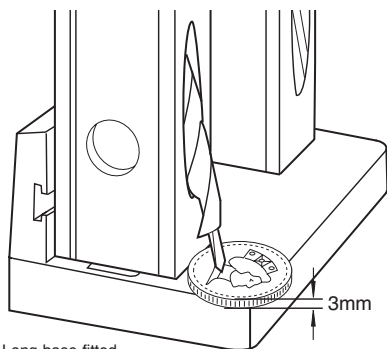

By adjusting the collar back or forward will give a deeper or shallower pocket. If the depth collar position is set too deep the screw may protrude

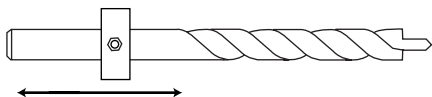

through the face of the joining piece. If too shallow the screw may not enter into the joint sufficiently.

When working with thin material (16mm) and mitres, the counter-bored hole will need to be shallower than standard. Shallower counter-bored holes will result in the head of the screw being closer to or even above the surface, this is acceptable in certain applications where the head of the screw is invisible from view.

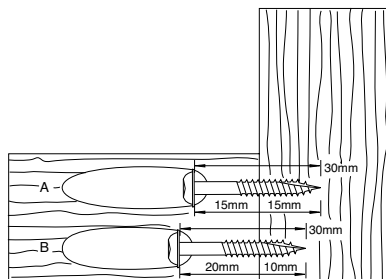
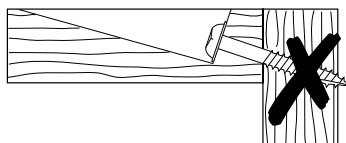
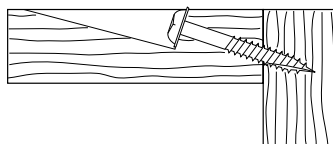

Before using the pocket hole jig for the first time, it is recommended that a number of trial cuts are made in waste timber as this will allow the drill to bed into the drill guide bushes in the columns. During the bedding in process there will be evidence of some metal swarf.

OPERATION



Material Thickness

Long Base

For timber from 16mm to 38mm the long base is used. If the material is thinner than the optimal 19mm thickness the screw will not exit in the centre and likewise if thicker material is used.

Even though the screw does not exit in the centre a tight joint will still be created. As the material gets thicker however it may be advisable to put the pocket holes on multiple sides of the component or use the short base.

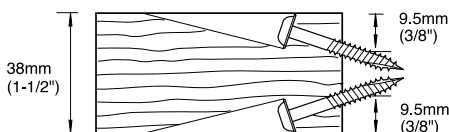
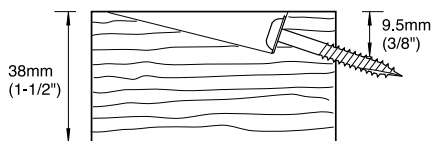
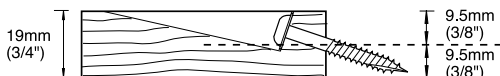

Short Base

For timber thicker than 22mm the short base is recommended to centre the pocket hole in the timber. This base is also recommended for use when repairing existing joints which need strengthening. For timber 22mm to 32mm thick set the collar 98mm from the drill tip and the base 7mm from the edge of the timber.

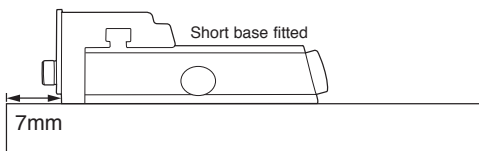
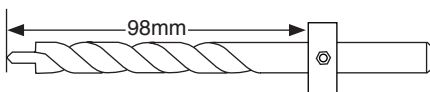

For timber 32mm to 38mm thick set the collar 110mm from the drill tip, and the base 19mm from the edge of the timber.

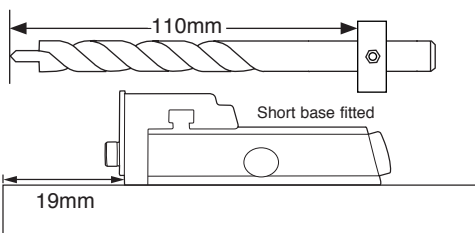

Please note these measurements are a guideline only. Adjustments may need to be made for different timber thicknesses. Trial cuts should be made in waste material before drilling into the workpiece.



When using the short base for repair work ensure that the pocket hole and drill heights are set correctly. This ensures the drill or screw does not come right through the component. Before any repair work is carried out it is advisable to drill a test pocket hole and test a screwed joint on similar material thickness beforehand.

Pocket Hole Spacing

When boring framing material, two pocket holes should be used to keep the timber from twisting. When working with long pieces of timber to create a board (jointing edge to edge) to make a table top for example, single pockets can be drilled at between 150mm to 200mm centres.

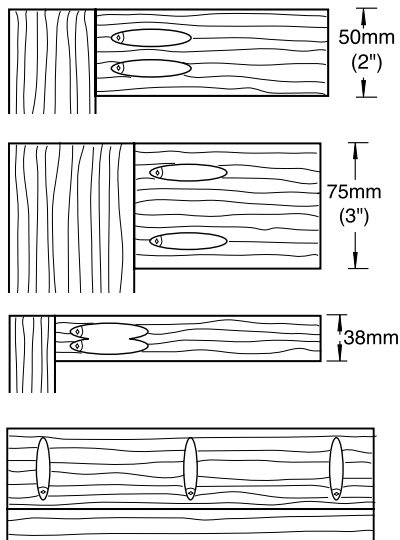

Drilling the Pocket Holes

Boring the counter-bored hole involves drilling with a stepped drill into one of the joint pieces.

- Once the collar depth and base is set, clamp the jig to the timber tightly using an 'F' clamp or bar clamp.



Make sure the jig and component are clamped securely before drilling.

- Fit the drill bit with depth collar already set into the chuck of the drill used.
- Place drill bit into top section of the bush hole in drill guide. Do not place the drill tip against the component.

- Switch on drill at full speed (clockwise direction) and drill into the component until the collar touches the bush. Gently pulling drill in and out whilst drilling will allow wood chips to clear more easily.
- Once depth is reached switch drill off and withdraw drill bit from drill guide.
- Repeat for other pocket hole and then remove component.
- Repeat operation for the remaining pieces.



Do not push hard on the drill until the drill pilot tip of the drill bit is fully into the work piece and the counterbore section is actually cutting.



Use a high drilling speed to increase drill life (2000 rpm or higher).



Keep the drill bit sharp.



Make sure drill bit is held in chuck securely. If the drill spins loose in the chuck the shock can break the drill bit tip.



Place the drill bit into the top section of the drill guide hole before spinning. Do not place the drill tip against the component until the drill is at full speed.

Assembling the Joint

Self-tapping pocket hole screws do not need to have pilot holes drilled, even in hardwoods. Other types of screws can work in the jig but the self-tapping screws reduce splitting in the timber and are hardened to reduce breakage. Whenever possible use glue on the joint unless it is necessary to disassemble the joint.

To aid assembly on corner joints, it is advisable to use a high batten, clamped to the bench. The components can be pushed against it to keep the two parts flush to each other, whilst screwing them together.

When assembling edge to edge joints it is advisable to use a face clamp to keep both parts flush. The face clamp can be adjusted to suit material thickness by adjusting the locking nut on the handle of the face clamp. The larger pad on the clamp should be on the face side of the material.

The screw should be driven into the component using a torque control screwdriving drill. The torque control allows control of the tightness of the screws into the wood and minimise the possibility of stripping the screw. The longer square drive screwdriver bit is used for most pocket hole screw driving applications. The shorter bit allows for use in tight spaces. The screwdriver bits have 1/4" quick change shanks and can be used directly into a drill chuck or more conveniently into a Trend Snappy quick change drill chuck Ref. SNAP/QC.

If a torque control screwdriver is not available start to screw with a conventional drill and then finish off by hand using a square drive hand screwdriver or the Trend Snappy Handriver Ref. SNAP/HAND/1.

If access to the screws are tight the screwdriver bits can be fitted into a 1/4" socket fitted to a ratchet or use a flexible shaft screwdriver.

After use, store jig carefully.

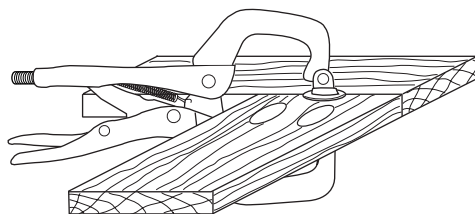
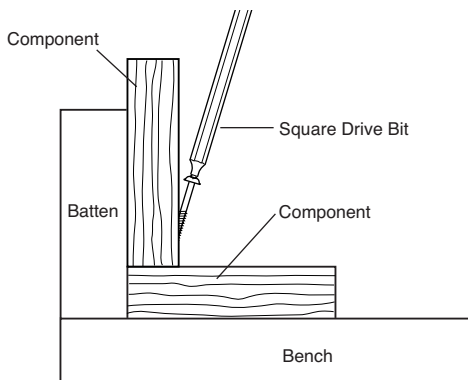

Ref. PH/CLAMP/F6 available as an accessory.

APPLICATIONS

Frame Corner Joints – faster and stronger than dowel and biscuits. Self clamping whilst glue is drying.

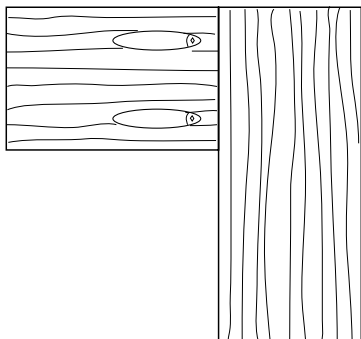

Square Corner Joints – faster and stronger than dowel and biscuits. Self clamping whilst glue is drying.

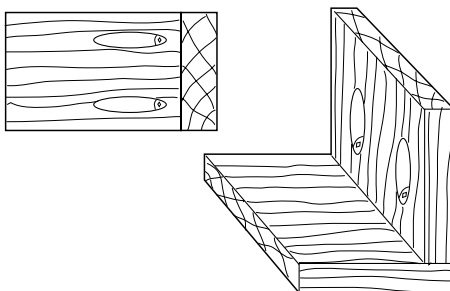

Mitred Frame Corner Joints – for narrow frames a single pocket hole is necessary. Cut the mitre and rout any rebates before boring the pocket holes. For material less than 50mm wide it may be necessary to tilt the pocket hole piece so that the hole is not perpendicular to the mitred edge.

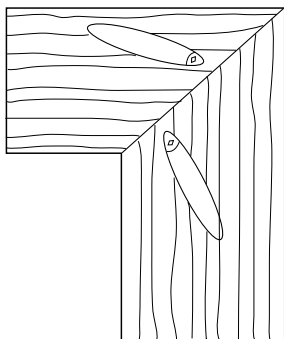

T- Joints – faster and stronger than dowel and biscuits. Self clamping whilst glue is drying.

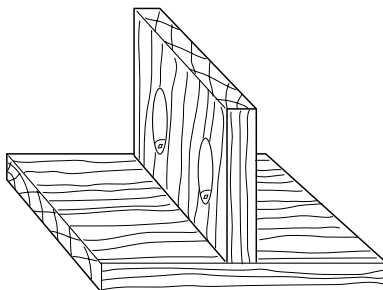

When changing material or joint application, test the depth of the drill and collar before drilling into the workpiece. Test drill in waste pieces of the same thickness. Then drill a screw into the pocket joint only and lay it against the jointing piece to see if screw depth is correct.

Angled Joints – eliminates difficult clamping up. The joint is created not by cutting each mitre to half the angle but by cutting angle on one joining piece and drilling pocket holes into the square piece. The method results in the mitred edge having an overhang, which will need to be removed by plane or sander.

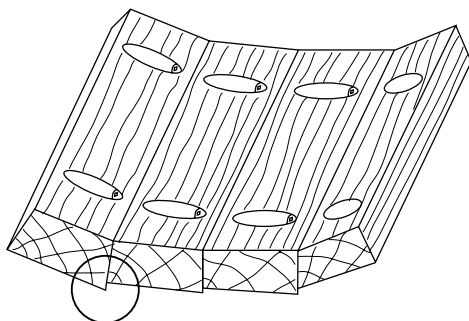
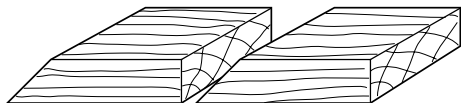

Curved Joints – this uses the same technique as the angled joint, but the angles will be shallower (5° to 15°). The overhang will need to be removed as previous.

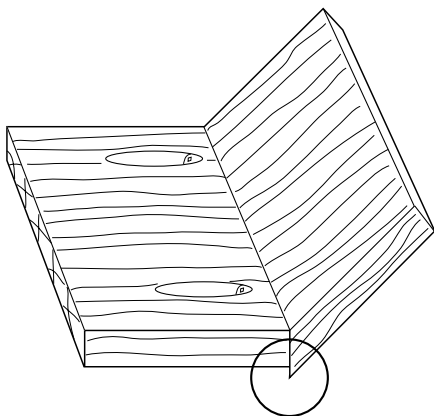

Mitred Corner Joints – joining two pieces with 45° mitres with the pocket jig is not advisable, however a 90° change of direction can be created by using a bevel-jointing piece. The joint comprises of a 90° infill piece with 45° mitres on both sides.

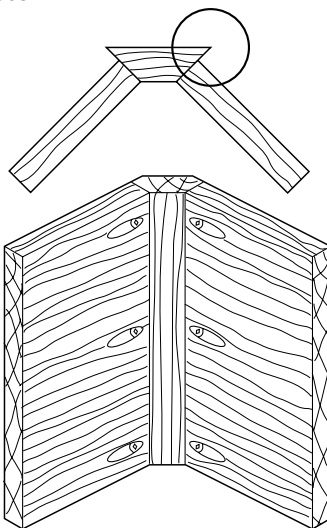
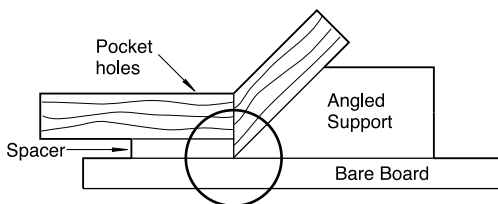

Plinths – faster and stronger than dowel and biscuits.

Edge to Edge Joints – allows narrow strips to be jointed to create wider boards such as a table top.

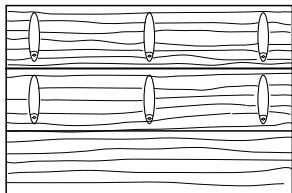

Edging of countertops or shelving – quick and easy way to join edging onto plywood, MDF or Particle board shelves.

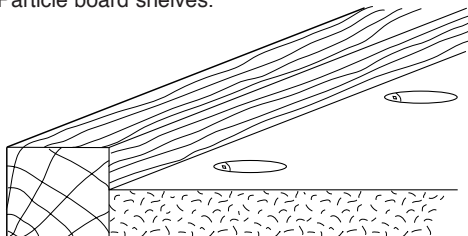

Post and Rail Joints – pocket holes allow strong table and chair joints. For fitting table tops to rails, the rails will need to be pocket hole drilled. To allow for the movement of the timber as it expands and contracts the hole must be slightly over size. This is achieved by lifting the rail about 3mm off the base of the jig. This should allow the pilot tip of the drill to break through the end of the timber, giving the screw space for some movement. Alternatively move the rail sideways slightly to drill another pocket hole (interlocking) allowing a slot for the screw.

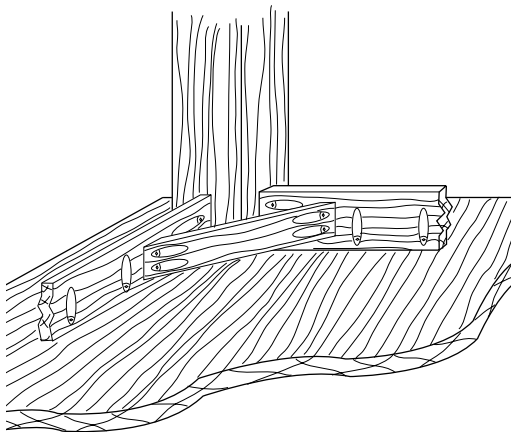

Jig making – very useful for jig making and temporary assembly operations. Ideal for routing jigs.

Framed Panel (Cabinet) Joints – pocket holes can be used for almost all framed cabinet carcass construction.

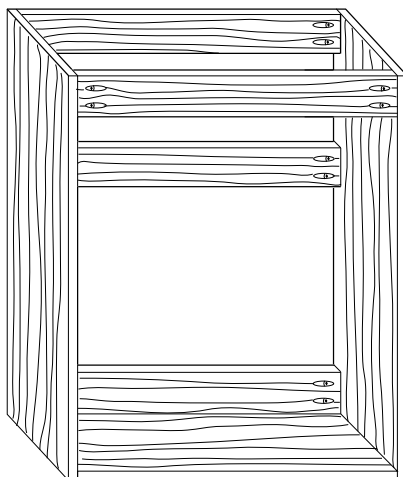
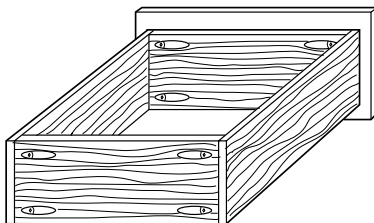

ACCESSORIES

Please use only Trend original accessories.

Self Tapping Screws Square Drive

Standard Thread No.7x30mm.

Pack 500

Ref. PH/7X30/500



Self Tapping Coarse Thread Screws Square Drive

Coarse Thread No.7x30mm.

For softer woods, plywood and particle board

Pack 500

Ref. PH/7X30/500C

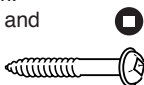

Quick Release Shank Drill Bit

Ref. PH/DRILL/95Q

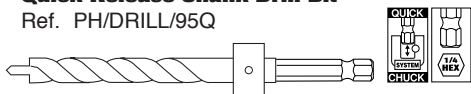

Pocket Hole Plug Cutter

A tool steel pellet cutter that is used in a pillar drill to allow plugs to be made to cover the pocket hole.

Allows plugs up to 52mm long to be created in end grain.

Ref. PH/PC/95

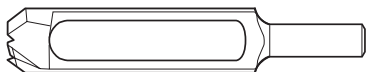

Face Clamp

Ref. PH/CLAMP/F6

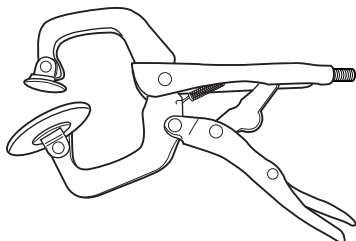

No.2 Square Drive Bit 75mm

Ref. SNAP/SQ/2A

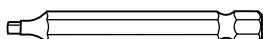

MAINTENANCE

Please use only Trend original spare parts and accessories.

The accessory has been designed to operate over a long period of time with minimum of maintenance. Continual satisfactory operation depends upon proper tool care and regular cleaning.

Cleaning

- Keep the threads and clamp mechanism clear of sawdust and resin build-up.
- Regularly clean with a soft cloth.

Lubrication

- Periodically lubricate the holes in the guide columns with PTFE dry lubricant.

Drill Bit Care

- Ensure the drill bit is sharp.
- Check tightness of depth collar set screw.

Storage

- After use store jig in its packaging or in a cupboard.

ENVIRONMENTAL PROTECTION



Recycle raw materials instead of disposing as waste.

Packaging should be sorted for environmental-friendly recycling.

The product and its accessories at the end of its life should be sorted for environmental-friendly recycling.

GUARANTEE

All Trend products are guaranteed against any defects in either workmanship or material, except products that have been damaged due to improper user or maintenance.

Please use only Trend original spare parts.

PH/JIG - SPARE PARTS LIST			v1.0 01/2014
No.	Qty.	Desc.	Ref.
1	1	Base Long	WP-PHJM/01
2	1	Base Short	WP-PHJM/02
3	2	Guide Column with Solid Bush	WP-PHJM/03
4	2	Machine Screw Cap M5 x 20mm Skt	WP-SCW/122
5	2	Hex Nut M5	WP-NUT/05
6	2	Scale Marker	WP-PHJM/06
7	2	Hex Screw Cap M5 x 14mm Skt	WP-SCW/123
8	0	Screw Pocket Hole Self Tapping Dome No.7 x 30mm Square Pack of 500	PH/7X30/500
9	1	Hex Key 2.5mm A/F	WP-AP/25
10	1	Depth Collar for Stepped Drill	PH/COLL/95
11	1	Stepped Drill 9.5mm (3/8") Diameter x 150mm Long HSS	PH/DRILL/95
12	1	Square Drive Screwdriver Bit No.2 x 150mm long	SNAP/SQ/2B
13	1	Hex Key 4mm A/F	WP-AP/04
14	1	Manual	MANU/PH/M

PH/JIG/M - SPARE PARTS DIAGRAM

v1.0 01/2014

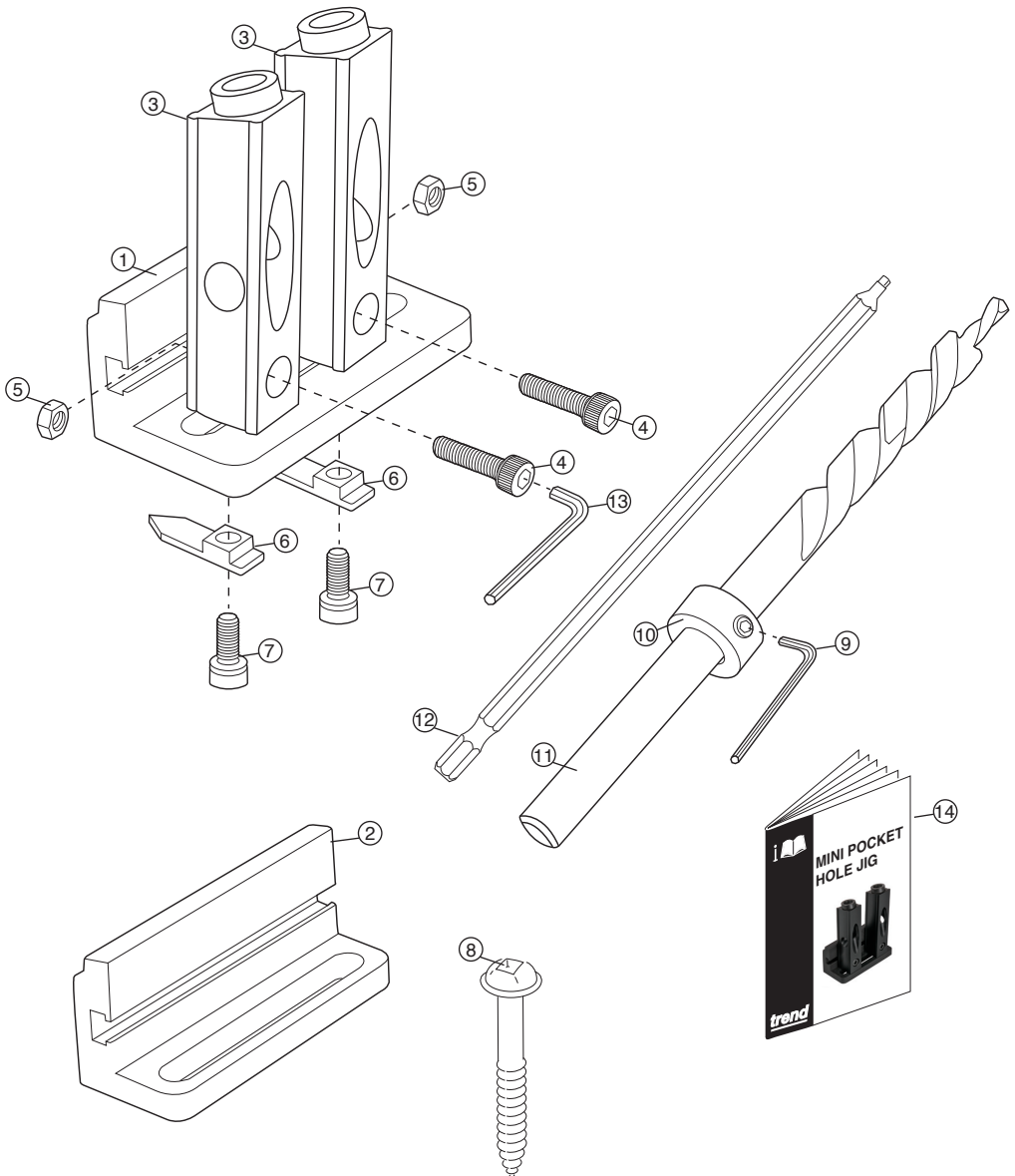

TROUBLE SHOOTING

Fault	Cause	Remedy
■ Drill guide columns move when drilling.	Fixing screw not tight.	Tighten fixing screw with hex key.
■ Screw protrudes through face of mating piece.	Depth collar set too high causing drill bit to drill too deep.	Adjust height of collar on drill bit with hex key.
	Jig base too close to edge of workpiece (on short base).	Move jig base further away from the edge of the workpiece.
■ Workpieces will not pull together tightly when being assembled.	Occurs on very hard woods, when threads of self tapping screw are holding on both pieces of material and pushing them apart.	Clamp material more tightly or adjust collar so drill point nearly breaks through first piece of material.
■ Workpieces do not sit flush or move when being assembled.	Screws tend to follow grain of the wood.	Clamp more securely to prevent material movement when assembling. Use face clamp for edge to edge joints.

MANU/PH/M V1.0



RECYCLABLE

Trend Machinery & Cutting Tools Ltd.
Odhams Trading Estate St Albans Road
Watford WD24 7TR England
Tel: 0044(0)1923 249911
technical@trendm.co.uk
www.trend-uk.com